



Please refer to the Schroeder America website (www.schroederamerica.com) for information relating to Schroeder America installation and Service Manuals, Instruction Sheets, Technical Bulletins, Service Bulletins, etc.

**INSTALLATION INSTRUCTION, PARTS LIST
AND CONFIGURATION GUIDE**

FOR THE

TEA DISPENSER (TEA URN)

Dispenser Model No. 925



NOTICE:

The information contained in this document is subject to change without notice.

SCHROEDER AMERICA MAKES NO WARRANTY OF ANY KIND WITH REGARD TO THIS MATERIAL, INCLUDING, BUT NOT LIMITED TO, THE IMPLIED WARRANTIES OF MERCHANTABILITY AND FITNESS FOR A PARTICULAR PURPOSE. SCHROEDER AMERICA shall not be liable for errors contained herein or for incidental consequential damages in connection with the finishings, performance, or use of this material.

This document contains proprietary information which is protected by copyright. All right reserved.

© Copyright 2008 by Schroeder America, all rights reserved.

THIS DOCUMENT CONTAINS IMPORTANT INFORMATION
This manual must be read and understood before the installation and operation of this dispenser.

Schroeder America
5620 Business Park • San Antonio, TX 78218
210.662.8200 • Fax: 210.667.2600 • www.schroederamerica.com
Toll-Free 877.404.2488

Rev: 08/11
PN: 805-0008

1. DISPENSER DIMENSIONS AND WEIGHT

- A. Single valve dispenser weight is 13 lbs.
- B. Single valve shipping weight is 15 lbs.

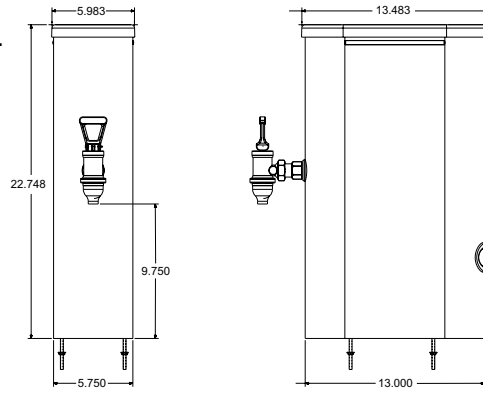

- D. Double valve dispenser weight is 14 lbs.
- E. Double valve shipping weight is 20 lbs.

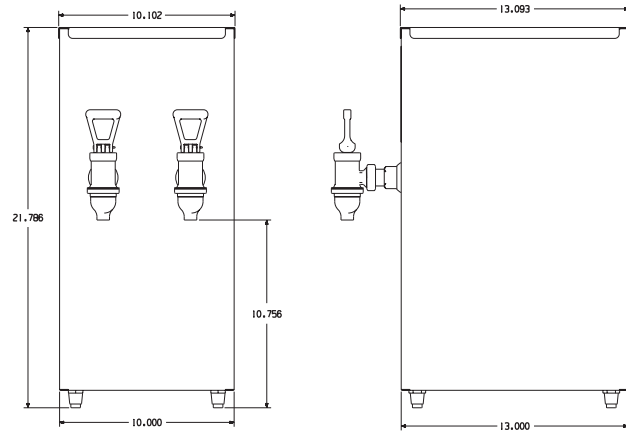

2. WATER AND SYRUP REQUIREMENTS

	<u>Minimum</u>	<u>Maximum</u>
Water/Soda	40 PSIG (2.8 kg/cm ²)	110 PSIG (7.73 kg/cm ²)
Syrup (Sugar)	20 PSIG (2.8 kg/cm ²)	70 PSIG (4.92 kg/cm ²)
Water/Soda	10 PSIG (2.8 kg/cm ²)	70 PSIG (4.92 kg/cm ²)

3. INSTALLATION

Water pipe connections and fixtures directly connected to a potable water supply shall be sized, installed and maintained in accordance with federal, state and local codes.

IMPORTANT

THIS EQUIPMENT TO BE INSTALLED WITH ADEQUATE BACKFLOW PROTECTION.

- A. The single oval tea urn may only be installed loose on the counter-top or mounted to the counter-top with the fastener package which is comprised of the following parts: (Kit # 670-0013)
 1. 4 only, P.N. 233-0004, Bolt, 10-24
 2. 4 only, P.N. 239-0001, Spacer
 3. 8 only, P.N. 243-0028, Nut, Hex, 10-24
 4. 4 only, P.N. 240-0017, Washer, Flat
- B. Attach the bolts to the inner support bracket using a washer and nut. Tighten the nut to keep the bolt firmly attached to the inner bracket.

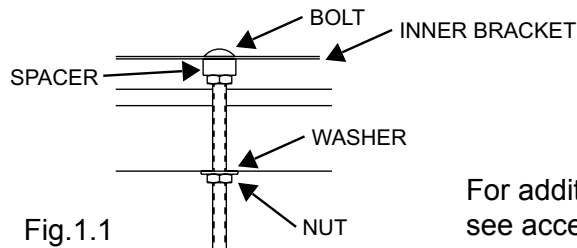

Fig.1.1

For additional mounting options, see accessories page.

- C. Using the template, locate the desired position of the urn and mark the center of the holes on the counter. Drill holes using 13/64 drill bit.
- D. Set urn on counter so that bolts protrude through holes.
- E. Mounting to counter

NOTE:

To comply with National Sanitation Foundation (NSF) requirements with the United States, unit base must be sealed to the counter-top.

- 1. Liberally apply silastic sealant (such as Dow Corning RTV 730 or equivalent) on base bottom edge.

NOTE:

DO NOT move unit after positioning, or the seal from base to counter will be broken.

- 2. Apply additional sealant around bottom of base. Seal must have a minimum 1/2" radius to prevent crevices and to ensure a complete seal.
- 3. Allow sealant to dry to MFG recommendations.
- F. Assemble washers and nuts to bolts from underneath the counter-top. Tighten firmly. **DO NOT OVER TIGHTEN!**
- G. Using a right angle beverage fitting supplied in the install kit, attach inlet water and concentrate tubes to the back of the flow control modules. Tubing can be routed either through a hole in the counter-top or through the access point in the back of the urn. (Be sure to use proper size hose clamps to secure tubing to inlet fittings).

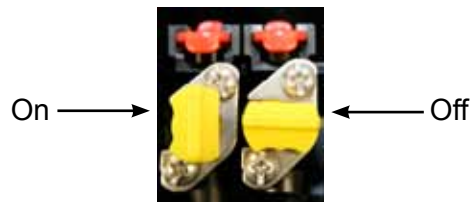

NOTE:

Be sure to lock inlet line fitting into FCM/MM module assembly using the red retainers before introducing product and water.

- H. See above
- I. Turn on water and syrup at source.
- J. Turn on water and syrup to flow controls by rotating yellow shut off knobs (see picture).
- K. Check for leaks.
- L. Remove nozzle and install ratio separator.
- M. Dispense about two (2) cups and dispose. Using a ratio cup check ratio. If not in spec use a small screwdriver to adjust. Clockwise increases flow. Counterclockwise decreases flow.
- N. Unit is now operational.

4. RATIO/BRIX

The Schroeder Dispenser has been thoroughly tested and sanitized prior to shipment. The installer will be required to ratio/brix the dispenser. A Schroeder Dispenser syrup separator or refractometer may be used.

NOTE:

Sugar free products require a syrup separator. Installer must cool or chill the product before brixing the system. Ratio will be different between cold product and warm product.

IMPORTANT

BEFORE RATIO/BRIXING SYSTEM, PURGE PRODUCT AND WATER THRU THE TEA URN DISPENSER TO ENSURE PROPER PRODUCT TEMPERATURE.

- A. To adjust water flow rate, turn off syrup side by rotating the yellow shut off, then pull handle to purge any remaining tea concentrate until clear liquid is dispensed. Capture water in a graduated cylinder (oz.) or measuring cup while timing the dispense. Divide the volume (oz.) of water by the time. This will equal the flow rate.

NOTE:

The Schroeder America Tea Dispenser is designed to flow 2.4oz/sec. or 12oz/5 sec. This is the proper setting for 5:1 ratio.

- B. To adjust flow control assembly, remove the red cap to expose the slotted yellow adjustment screw (Fig 2.1). To regulate flow, turn clockwise to increase flow and counterclockwise to decrease flow. If the flow control assembly contains a slotted green adjustment screw, it is mechanical. To regulate flow, turn counterclockwise to increase flow and clockwise to decrease flow, rate (opposite flow control).

Slotted
Adjustment
Screw



Fig.2.1



Fig.2.2

Metering Screw

- C. To achieve the proper water flow rate, adjust the yellow/green screw within the flow control module. For the mechanical application adjust the green metering screw (Fig.2.2).

NOTE:

Depending on the pressure of the incoming plain water, the maximum flow may not be achievable. There are two solutions to this problem.

- 1) Use slower flow rate. This will require ratio/brix adjustment.
- 2) Add a water booster to the system.

- D. To Ratio/Brix the final product, remove dispensing nozzle from valve.
- E. Replace dispensing nozzle with the Schroeder America syrup separator nozzle. Rotate the separator in position to ensure seal against the diffuser.
- F. Adjust syrup flow to required ratio.

5. CLEANING AND SANITIZING

The Schroeder America Dispenser is shipped from the factory cleaned and sanitized in accordance with NSF guidelines. The dispenser must also be cleaned and sanitized after installation is complete. It is recommended that the operator provide continuous maintenance as required by the manual and/or state and local guidelines to ensure proper operation.

A. External/Internal Cleaning

Cleaners (ivory liquid, calgon, etc.) should be mixed with clean potable water at a temperature of 90 to 110 degrees F. The acceptable mixture ratio is one ounce of cleanser to two gallons of water. Any NSF approved equivalent cleaner may be used. Rinsing must be thorough using clean potable water.

B. Internal Cleaning

1. Remove top cover.
2. Wipe inside of the Tea Urn with a clean cloth mixed with the cleaner.
3. Inspect to make sure any product residue has been removed.
4. Dry with a clean soft cloth.

IMPORTANT

DO NOT USE A CAUSTIC BASED, PERFUMED, OR ANY CLEANER THAT CAN NOT BE EASILY RINSED.

C. Sanitizing

Cleaning and Sanitizing are not required for potable water circuits. The potable water lines should remain connected during the cleaning procedures for the concentrate circuits to avoid contamination.

It is recommended that the nozzle be removed and cleaned daily.

The stainless steel urn can be cleaned by wiping with a cloth soaked with warm cleansing detergent. Inspect the hose to ensure all residue is removed. Abrasive cleaning or scouring pads should not be used as they will scratch the urn finish.

1. Disconnect concentrate container from product line.
2. Attach product line to container containing sanitizing solution mixed to mfg. recommendations (50 ppm is recommended)
 - a. Using yellow shut off, turn incoming water off.

NOTE:

Sanitizing solution temperature should be between 70° to 100° F (max).

3. Prepare enough solution to sanitize from the concentrate source to the tea urn dispenser.

NOTE:

Alternate - using a fitment removed from a bag in box container. Attach fitment to concentrate fitting. Prepare sanitizing solution in a container and set fitment/fitting assembly in solution.

4. Pull tea urn dispenser handle, solution will begin to flow towards dispensing valve.
5. When color turns clear concentrate line is full of sanitizer solution.
6. Wait 15 minutes.
 - a. Reconnect concentrate product line.
7. Purge sanitizer from line with concentrate product.
8. Purge until concentrate is flowing from dispensing valve.
9. Using yellow shut off, turn incoming water on.
10. Taste the beverage to verify that there is no off taste.

WARNING

FLUSH SANITIZING SOLUTION FROM CONCENTRATE LINE AS INSTRUCTED. RESIDUAL SANITIZING SOLUTION LEFT IN SYSTEM COULD DAMAGE LINES AND DISPENSER PARTS. IT MAY ALSO CREATE A HEALTH HAZARD.

6. TROUBLE SHOOTING

- A. No water dispensed
 - Check water supply
 - Check shut-off (is it open)
 - Check ratio/brix adjustment
 - Line plugged

- B. No syrup dispensed
 - Check C02 pressure
 - Check for product
 - Check shut-off
 - Check ratio/brix adjustment
 - Line plugged

- C. Weak product taste
 - Check ratio/brix adjustment
 - Check for plugged line
 - Check shut-off - completely open
 - Check syrup supply

- D. Strong product taste
 - Check ratio/brix adjustment
 - Check syrup C02
 - Check water supply

NOTES:

NOTES:

OVAL CAN ASSEMBLY

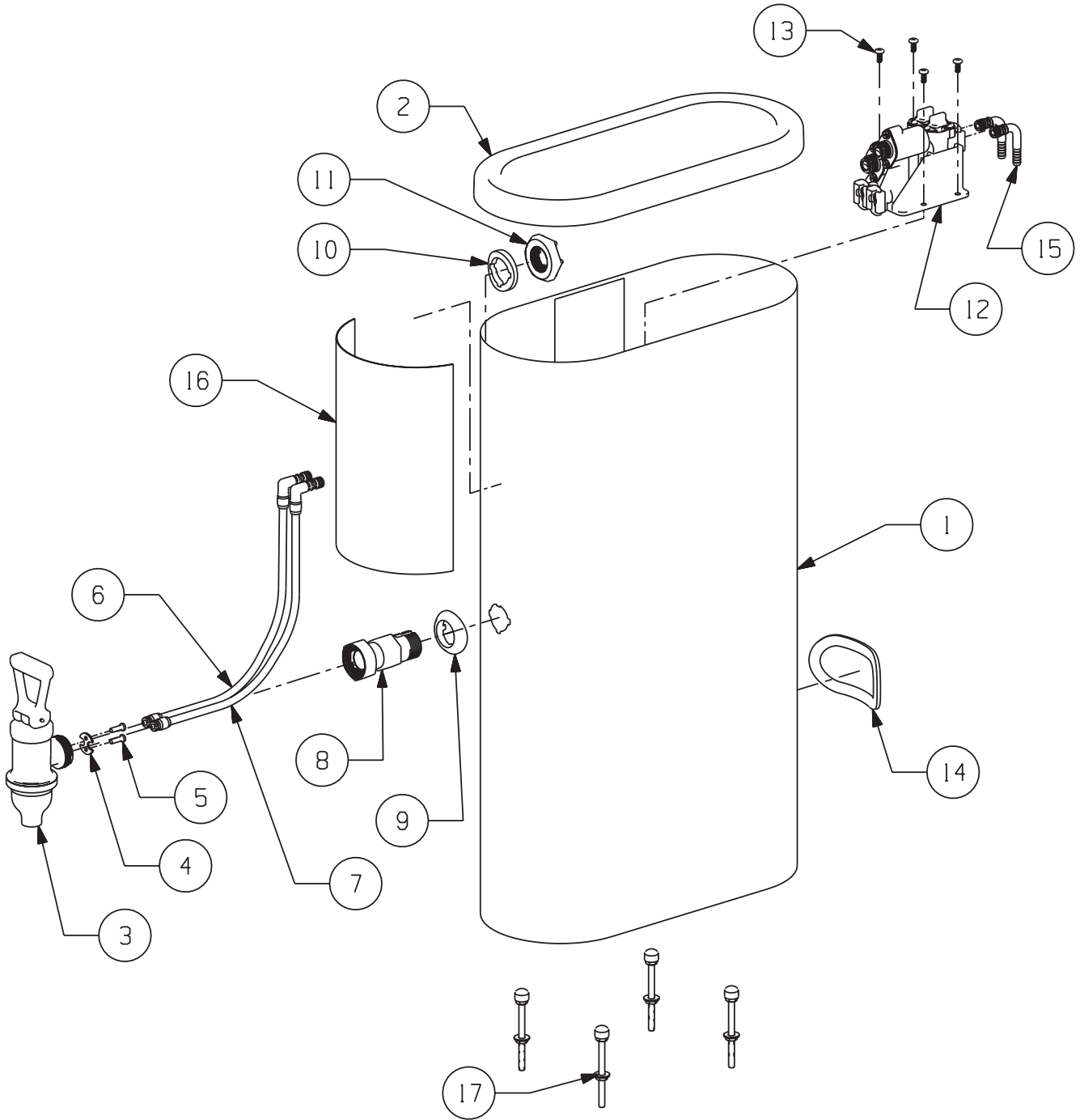

OVAL CAN ASSEMBLY

OVAL ASSEMBLY		
ITEM	SCHROEDER PN	DESCRIPTION
1	634-0031	CAN ASSY, 1V, OVAL, 5.75"
2	265-0350	LID, OVAL, 5.75"
3	637-0005	ASSY, VALVE, POSTMIX
4	256-0021	PLATE, VALVE, TEA
5	224-0006	SCREW, 6-19x.500, PLASTITE, PH, PHD
6	632-0110	SUB-ASSY, WATER, PMV
7	632-0111	SUB-ASSY, S1, PMV
8	645-0173	SHANK ASSY, PMV
9	265-0374	SPACER, PMV TO 5.75" CAN
10	265-0377	SPACER, INSIDE, 5.75" CAN
11	243-0030	NUT, HEX, 1-16, SS
12	660-1003	VALVE/BRACKET ASSY, 2V, BLK, TEA
13	220-0037	SCREW, 8-32x.375, PH, PHD, 18-8SS
14	210-0030	GROMMET,CAN,BACK,TEA
15	670-0014	PKG, INSTALL, 2 EA 3/8 X 1/4 90 DEG FITTINGS
17	670-0013	PACKAGE,INSTALL,SCREWS,TEA URN - FOR MOUNTING TO COUNTER WITH NO BASE
AVAILABLE GRAPHICS		
16	812-****	GRAPHICS, TEA URN - PARTIAL AND FULL WRAPPERS AVAILABLE
AVAILABLE ACCESSORIES		
	670-0012	PKG, INSTALL, 2 EA 3/8 X 3/8 90 DEG FITTINGS
	675-0049	KIT,DRIPTRAY/CUPREST,5.75" URN
	675-0050	KIT,BASE,W/OUT EXTENSION,5.75" URN
	675-0051	KIT,BASE,W/ EXTENSION,5.75" URN
	675-0052	KIT,BASE AND DRIPTRAY,5.75" URN
	675-0059	KIT,ROUND FEET AND SCREWS FOR BASE,TEA
	675-0060	KIT,SQUARE FEET FOR DRIPTRAY,TEA
OTHER AVAILABLE KITS		
	675-0042	KIT, RETAINER, & SCREWS, PMV : ITEMS 4 AND 5
	675-0043	KIT, POSTMIX VALVE : ITEMS 3, 4, AND 5
	675-0044	KIT, SHANK ASSY, PMV: ITEMS 8, 9, 10, AND 11

SQUARE CAN ASSEMBLY

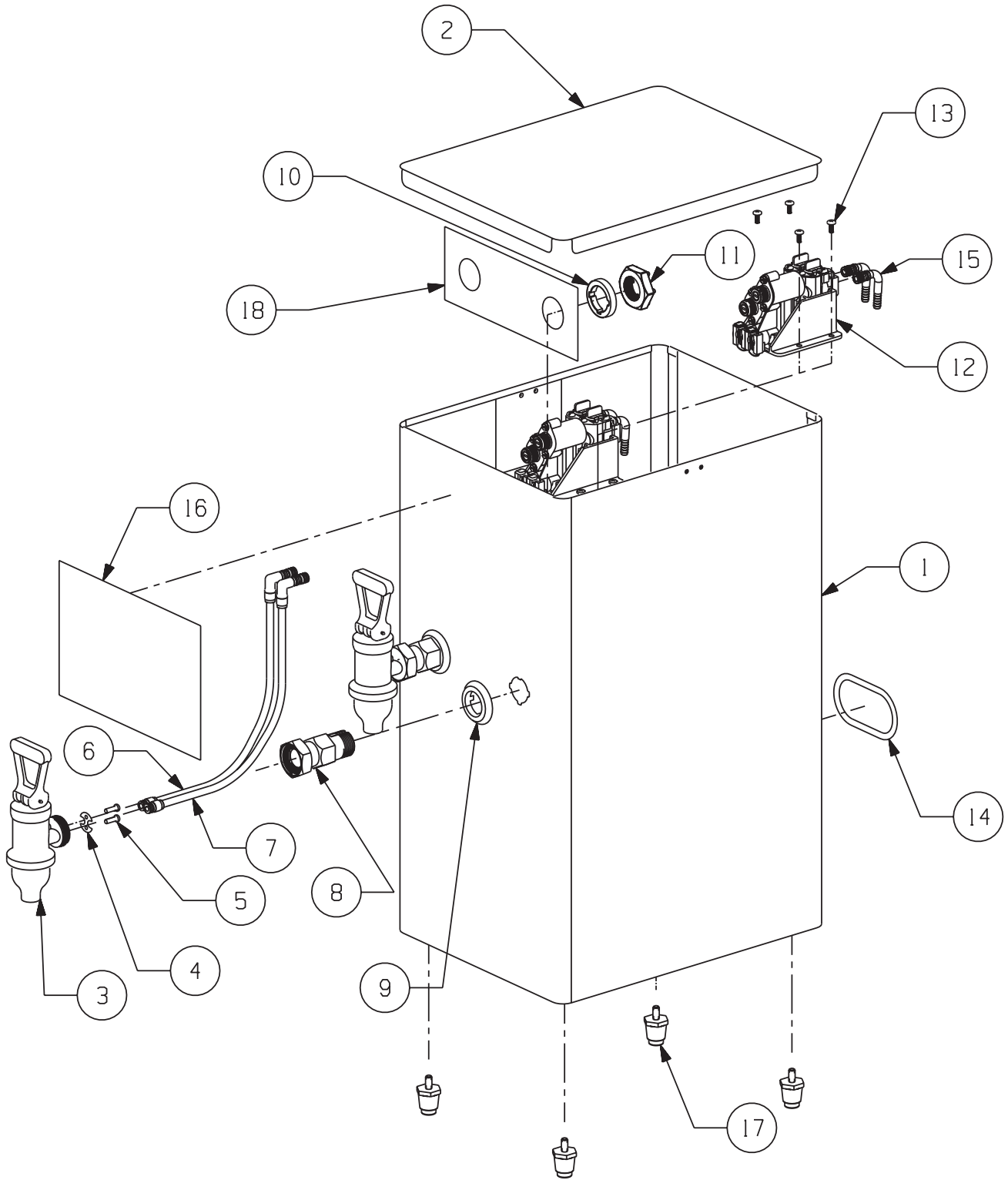

SQUARE CAN ASSEMBLY

SQUARE ASSEMBLY		
ITEM	SCHROEDER PN	DESCRIPTION
1	663-0002	FRAME ASSY, WELDED, SQUARE URN, 2V
2	319-0273	LID, SQUARE, 2V, TEA URN
3	637-0005	ASSY, VALVE, POSTMIX
4	256-0021	PLATE, VALVE, TEA
5	224-0006	SCREW, 6-19x.500, PLATITE, PH, PHD
6	632-0110	SUB-ASSY, WATER, PMV
7	632-0111	SUB-ASSY, S1, PMV
8	645-0173	SHANK ASSY, PMV
9	265-0385	SPACER, PMV TO SQUARE CAN
10	265-0386	SPACER, INSIDE, PMV TO SQUARE CAN
11	243-0030	NUT, HEX, 1-16, SS
12	660-1003	VALVE/BRACKET ASSY, 2V, BLK,
13	220-0037	SCREW, 8-32x.375, PH, PHD, 18-8SS
14	210-0030	GROMMET,CAN,BACK
15	670-0016	PKG, INSTALL, 4 EA 3/8 X 1/4 90 DEG
17	234-0003	LEG, PLASTIC, BLACK, ADJUSTABLE
18	319-0275	PLATE, 2V SQ TEA URN
AVAILABLE GRAPHICS		
16	812-****	GRAPHICS, TEA URN - PARTIAL AND FULL AVAILABLE
AVAILABLE ACCESSORIES		
	670-0015	PKG, INSTALL, 4 EA 3/8 X 3/8 90 DEG
OTHER KITS AVAILABLE		
	675-0042	KIT, RETAINER, & SCREWS, PMV : ITEMS 4 AND 5
	675-0043	KIT, POSTMIX VALVE : ITEMS 3, 4, AND 5
	675-0044	KIT, SHANK ASSY, PMV: ITEMS 8, 9, 10, AND 11

FLOW CONTROL ASSEMBLY

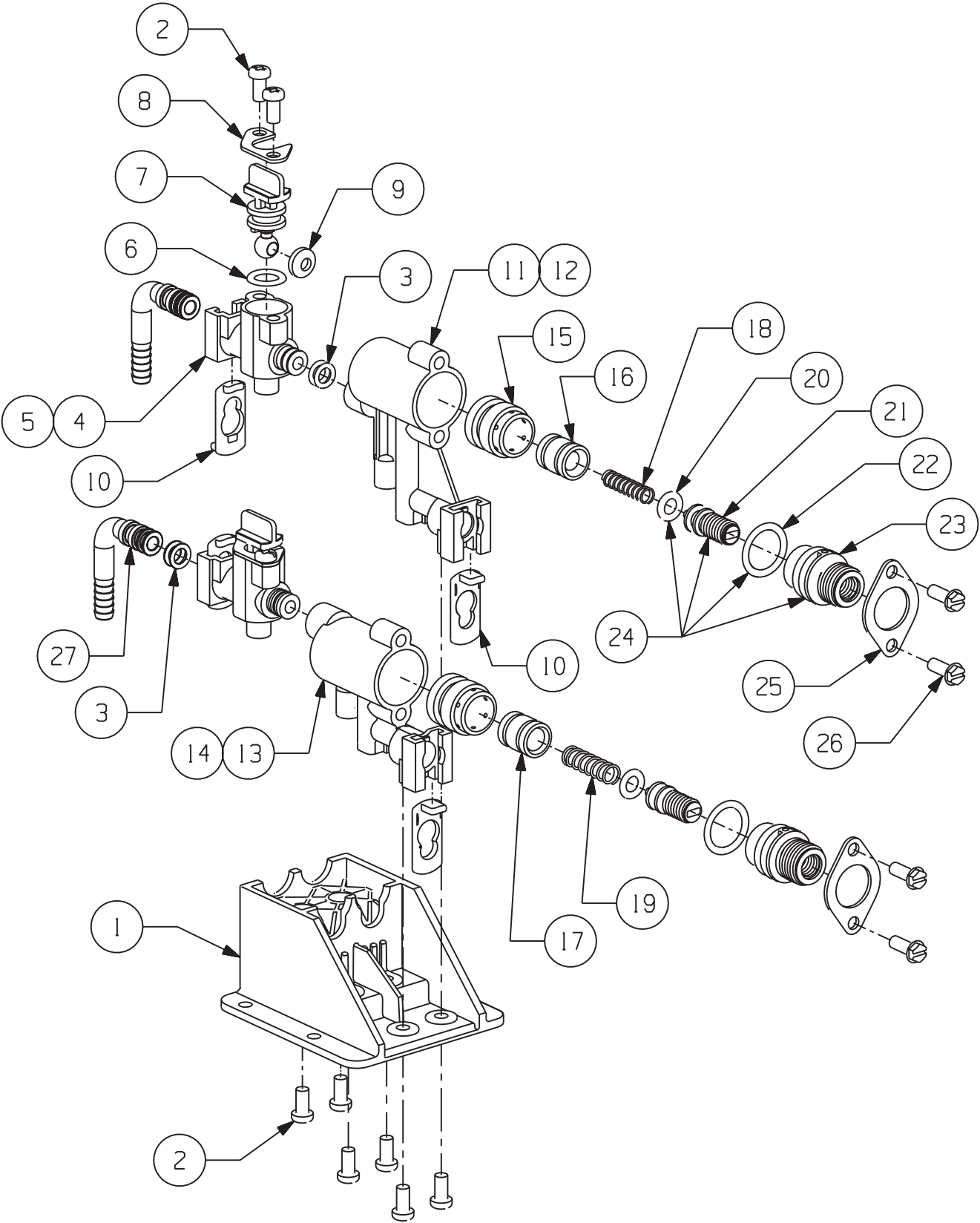

FLOW CONTROL ASSEMBLY

FLOW CONTROL ASSEMBLY		
ITEM	SCHROEDER PN	DESCRIPTION
1	265-0362	BRACKET,MTG, VALVE, TEA
2	224-0002	SCREW, 8-16x.375, PLASTITE, PHSL, PHD
3	208-0010	O-RING, 2-010
4	625-0034	BACKBLOCK SUB-ASSY, BLACK - WITH 208-0010
5	637-0003	ASSY, VALVE, BACKBLOCK, BLACK - COMPLETE
6	208-0110	O-RING, 2-110
7	625-0009	STEM ASSY, SHUT OFF - WITH 208-0110
8	256-0011	RETAINER, STEM
9	265-0043	WASHER, STEM
10	265-0063	RETAINER, CLIP, FITTING
11	639-0030	ASSY, FLOW CTRL, SYRUP, BLK, TEA
12	631-0033	SUB ASSY, BODY, FLOW CTRL, SYRUP,1, BLK
13	639-0029	ASSY, FLOW CONTROL, WATER, NAT W/ BLK BONNET
14	631-0017	SUB ASSY, BODY, FLOW CONTROL, 2, NAT
15	277-0001	SLEEVE, WATER/SYRUP
16	277-0008	PISTON, SYRUP, .088
17	277-0010	PISTON, WATER, .140
18	215-0002	SPRING, SYRUP
19	215-0003	SPRING, WATER
20	208-0108	O-RING, 2-108
21	625-0035	PLUG ADJUSTER SUBASSY,YELLOW,TEA - WITH 208-0108
22	208-0114	O-RING, 2-114
23	625-0007	BONNET SUB-ASSY, BLACK - WITH 208-0114
24	631-0078	PLUG ADJUST ASSY, BLACK W/ YELLOW PLUG
25	256-0010	RETAINER, BONNET
26	224-0001	SCREW, 8-16x.500, PLASTITE, SL, HHD
27	625-0011	ASSY, 90 DEG, .375 DOLE x.375 BARB - WITH 208-0010
	625-0013	ASSY, 90 DEG, .375 DOLE x.250 BARB - WITH 208-0010
KITS AVAILABLE		
	670-0012	PKG, INSTALL, 2 EA 3/8 x 3/8 90 DEG FITTINGS
	670-0014	PKG, INSTALL, 2 EA 3/8 x 1/4 90 DEG FITTINGS
	675-0005	KIT, MECHANICAL ORIFICE CONTROL

POST MIX VALVE ASSEMBLY

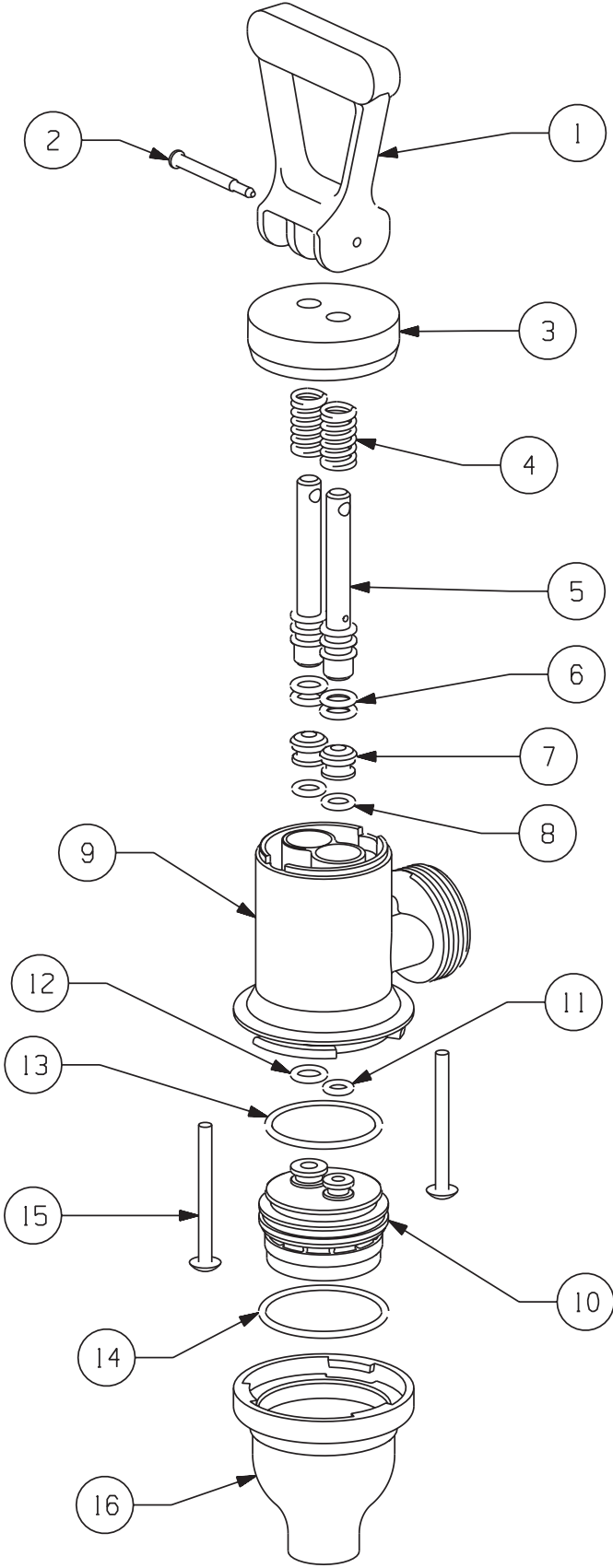

POST MIX VALVE ASSEMBLY

POSTMIX VALVE ASSEMBLY		
ITEM	SCHROEDER PN	DESCRIPTION
1	265-0316	HANDLE, POSTMIX VALVE
2	279-0076	RETAINER, PIN, PMV
3	631-0079	CAP ASSEMBLY, PMV
4	215-0008	SPRING, POSTMIX VALVE
5	625-0031	PISTON ASSY, POSTMIX VALVE - WITH 208-0010-429
6	208-0010-429	O-RING, 2-010, LUBRICATED
7	631-0080	VALVE SEAT ASSY, PMV - WITH 208-0009
8	208-0009	O-RING, 2-009
9	265-0279	BODY, VALVE, PMV
10	631-0069	NOZZLE ASSY, POSTMIX VALVE - WITH O-RINGS
11	208-0008	O-RING, 2-008
12	208-0010	O-RING, 2-010
13	208-0023	O-RING, 2-023
14	208-0025	O-RING, 2-025
15	220-0039	SCREW, 6-32 x 1.500, PH, THD, SS
16	265-0305	BODY, NOZZLE, POSTMIX, BLACK
	637-0005	ASSY, VALVE, POSTMIX

SHANK AND TUBE ASSEMBLY

WHILE INDIVIDUAL PARTS ARE AVAILABLE,
SUPPLIER RECOMMENDATION IS TO
PURCHASE ENTIRE TUBING ASSEMBLY

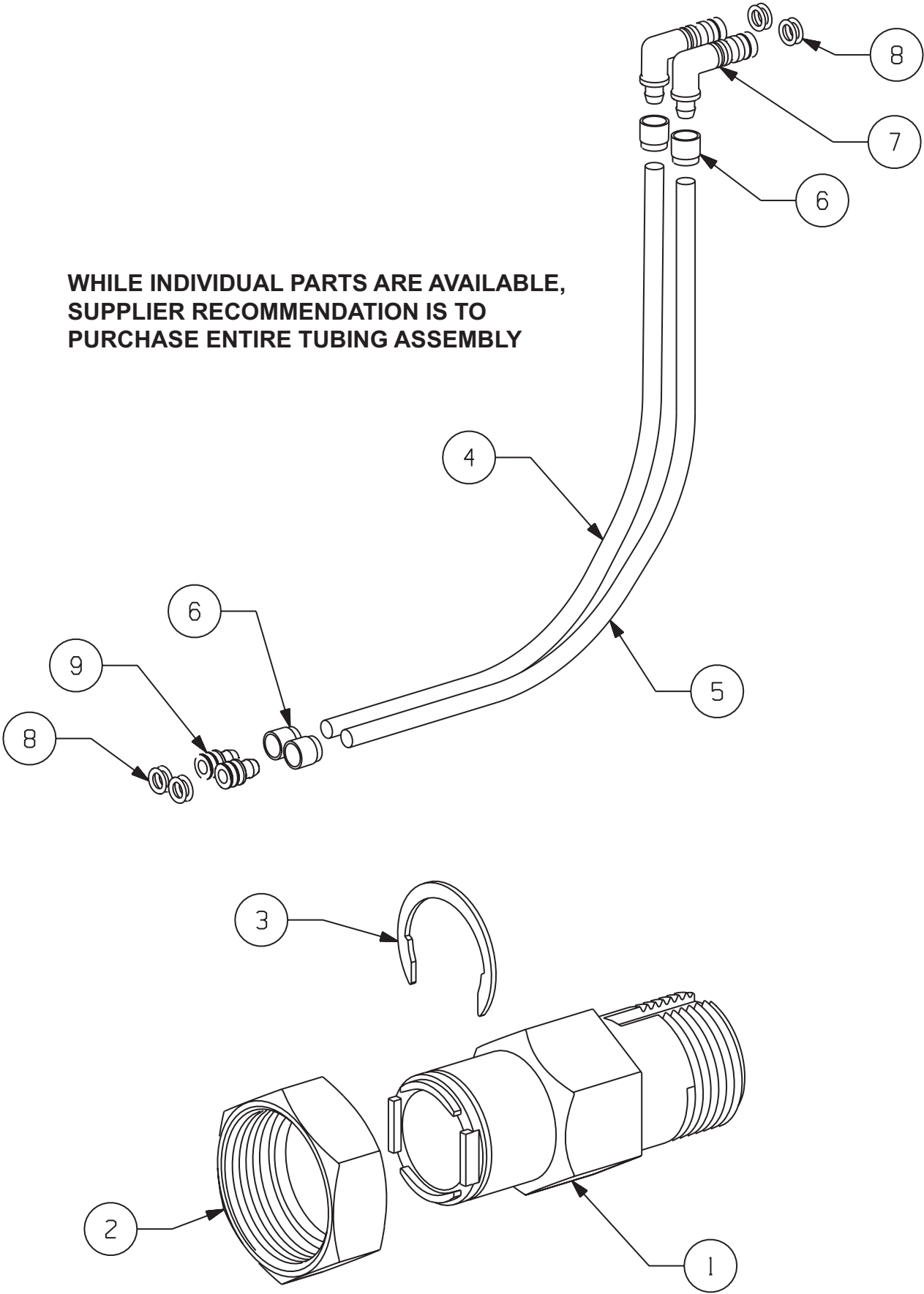

SHANK AND TUBE ASSEMBLY

TUBE ASSEMBLIES		
ITEM	SCHROEDER PN	DESCRIPTION
	632-0110	SUB-ASSY, WATER, PMV
	632-0111	SUB-ASSY, S1, PMV
4	030-0029	TUBE, .218 x .032, WATER, PMV
5	030-0030	TUBE, .218 x .032, S1, PMV
6	265-0380	FERRULE, PMV
7	626-0005	FITTING ASSY, 90 DEG, PMV
8	208-0010-429	O-RING, 2-010, LUBRICATED
9	626-0004	FITT ASSY, INLET, PMV
		SHANK ASSEMBLY
	645-0173	SHANK ASSY, PMV
1	265-0376	SHANK, VALVE, PMV
2	243-0017	NUT, SHANK, VALVE, TEA
3	248-0006	CLIP, TRUARC, .938

OVAL CAN BASE/DRIPTRAY ACCESSORIES

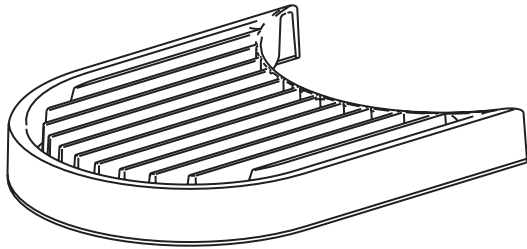

KIT, DRIPTRAY/CUPREST, 5.75" URN
P.N. 675-0049

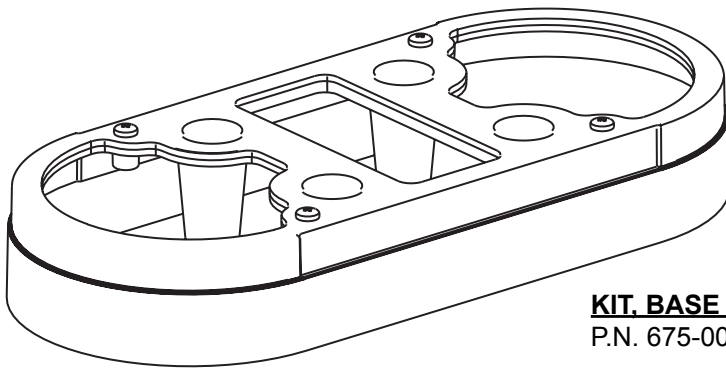

KIT, BASE W/OUT EXTENSION, 5.75" URN
P.N. 675-0050

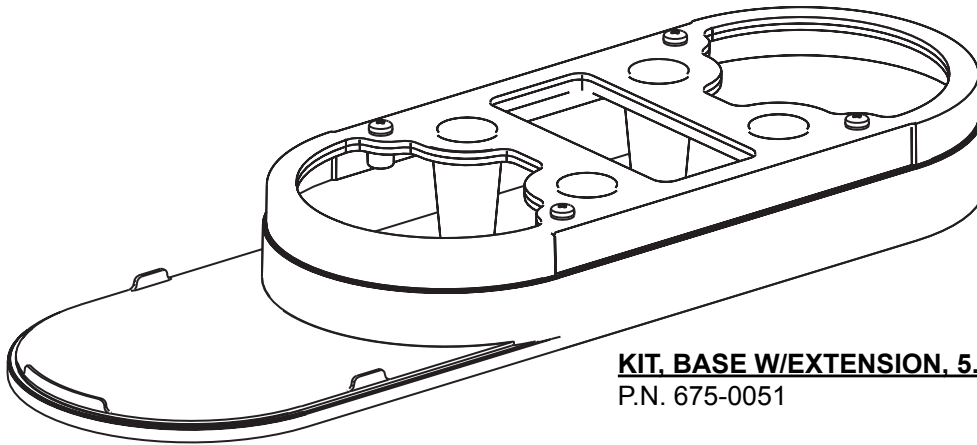

KIT, BASE W/EXTENSION, 5.75" URN
P.N. 675-0051

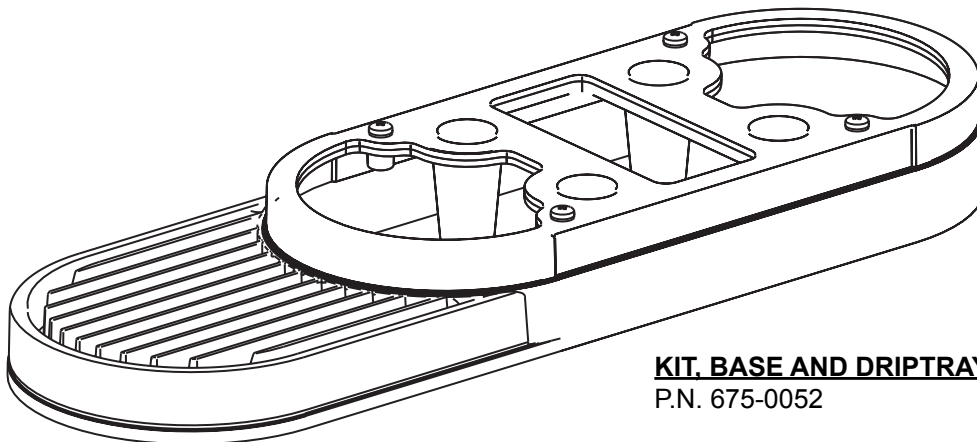

KIT, BASE AND DRIPTRAY, 5.75" URN
P.N. 675-0052

ACCESSORIES

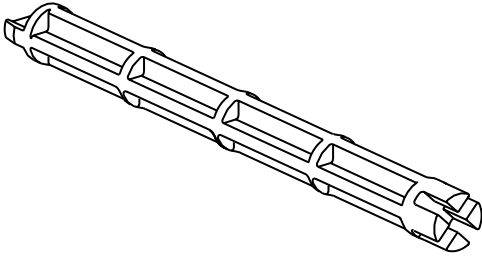

SHUT OFF TOOL
P.N. 316-0005

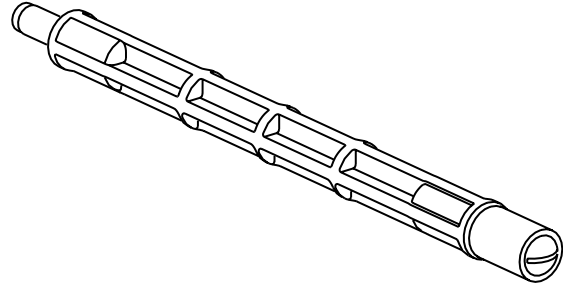

FLOW CONTROL TOOL
P.N. 316-0006

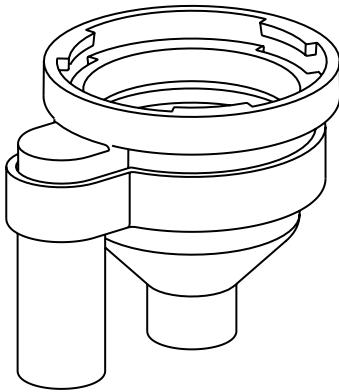

SEPARATOR
P.N. 316-0010

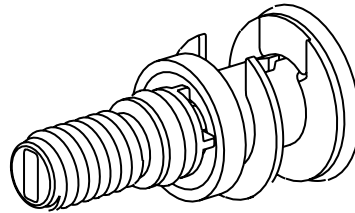

KIT, MECHANICAL CONTROL
P.N. 675-0005

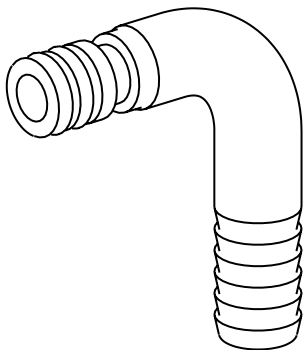

3/8 90 DEG BARB.
STAINLESS STEEL FITTING
P.N. 625-0011

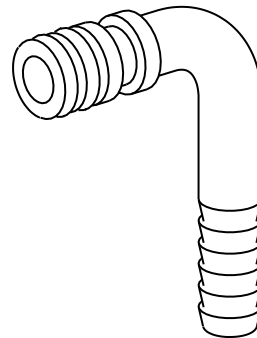

1/4 90 DEG BARB.
STAINLESS STEEL FITTING
P.N. 625-0013



BEVERAGE DISPENSER (TEA URN) PARTS AND EQUIPMENT LIMITED COMMERCIAL WARRANTY

Schroeder America warrants to the original purchaser from Schroeder America, or its Distributors, who purchased solely for commercial or industrial uses, or for resale in the ordinary course of business, that each of the Products covered by this Commercial Warranty shall be free from defects in material and or workmanship, under normal and proper use and service conditions. Any Products covered by this Commercial Warranty (including components thereof) demonstrated to have been defective when shipped by Schroeder America, will be either repaired or replaced (with new or rebuilt replacement) at the sole discretion of Schroeder America. A product or component thereof covered by this Commercial Warranty supplied as Warranty Replacement will assume the balance of the Period of Warranty applicable to the original measured from the date of replacement. This Commercial Warranty does not include, and Schroeder America will not assume or pay, the expense of any repair, replacement, analysis or any other service or parts furnished by any party other than Schroeder America unless specifically authorized in writing by Schroeder America. This Commercial Warranty does not include labor for diagnosis, repair, removal, or installation on any products or components.

Products covered by this Commercial Warranty are beverage dispensing equipment (Tea Urn) manufactured or sold by Schroeder America after the date hereof (not excluded hereinafter) and this Commercial Warranty is further limited to the use of that equipment in connection with tea, juice, soft drinks and commodities for which use of the particular product has been identified by Schroeder America.

Specific exclusions to this Commercial Warranty are OEM Sales, seals, o-rings, and rubber parts, in contact with water or the product dispensed and which have become inoperative due to scale or chemical change. This Commercial Warranty also **specifically excludes** damage resulting from, abuse, accident, alteration, misuse, neglect, unauthorized repair, improper cleaning or failure to follow installation, operating or maintenance instructions.

The Period of Warranty is (i) thirty-nine (27) months from the date of manufacture, or (ii) thirty-six (24) months from the date of sale of a product covered hereby, whichever time period elapses first.

The product covered by this Commercial Warranty, or components thereof, must not be returned to Schroeder America without prior authorization. Instructions for return will be given with any such authorization. All returned products and or parts must be shipped prepaid to Schroeder America. Return shipping costs of repaired or replacement products or parts will be prepaid by Schroeder America except to original purchasers in Hawaii or Alaska, in which case Schroeder America will pay shipping costs only to Seattle, San Francisco, or Los Angeles respectively. Schroeder America will not accept collect shipments. Replaced products or parts become the property of Schroeder America. Any product or parts returned to Schroeder America under the terms of this Commercial Warranty must be accompanied by a Returned Goods Tag, properly filled out as to unit model number and serial number and detailed explanation of failure. Returned Goods Tags will be furnished by Schroeder America. Except for descriptions of size, quantity and type, which may appear on Schroeder America invoices and other written materials, and except for any statements of conformity of Schroeder America product with specification of certain industry, government or professional organizations standards, which may appear as product information disclosures in Schroeder America literature and other documents from time to time, THIS COMMERCIAL WARRANTY IS IN LIEU OF AND EXCLUDES ALL OTHER WARRANTIES, EXPRESS OR IMPLIED, INCLUDING WARRANTIES OF MERCHANTABILITY AND FITNESS FOR A PARTICULAR PURPOSE.

SCHROEDER AMERICA LIABILITIES ARE LIMITED SOLELY AND EXCLUSIVELY TO THE REPLACEMENT OR REPAIR OF THE DEFECTIVE PRODUCT OR REFUND OF THE PURCHASE PRICE OF SAID PRODUCT. SCHROEDER AMERICA IS NOT LIABLE FOR ANY SPECIAL, INCIDENTAL OR CONSEQUENTIAL DAMAGES OF ANY KIND WHATSOEVER, WHETHER ANY CLAIM FOR RECOVERY IS BASED ON THEORIES OF CONTRACT, NEGLIGENCE OR TORT. Without limitation, these liabilities do not include shipping charges, labor, installation or any other losses or expenses incurred on operation or installation of any replaced, repaired, or returned product or component. In those Jurisdictions where liability for damages cannot be disclaimed, the original purchaser's recovery shall not exceed the cost of the product to which this Commercial Warranty may apply.

Schroeder America neither assumes, nor authorizes any salesperson, distributor, employee, agent, or other person to assume for it, any liability or obligation of any kind which is different from the terms of this Commercial Warranty.

SCHROEDER AMERICA MAKES NO WRITTEN WARRANTY OF ANY KIND WHATSOEVER TO ANY PURCHASER WHO BUYS FOR PERSONAL, FAMILY OR HOUSEHOLD USE.

Schroeder America may in its discretion direct an Authorized Service Center reasonably proximate to the Original Purchaser to perform its obligations under this Commercial Warranty. That Service Center may also perform such other services as the purchaser may require at purchaser's expense.

Schroeder America
5620 Business Park • San Antonio, Texas 78218 • www.schroederamerica.com
Phone: 210.662.8200 • Fax: 210.667.2600 • Toll Free: 877.404.2488

REV: 10/14/10
PN: 810-0030

