**INSTALLATION INSTRUCTION, PARTS LIST
AND CONFIGURATION GUIDE**

FOR THE

**NON-CARBONATED
BEVERAGE DISPENSER (STARLINE)**

Dispenser Model No. 900



NOTICE:

The information contained in this document is subject to change without notice.

SCHROEDER AMERICA MAKES NO WARRANTY OF ANY KIND WITH REGARD TO THIS MATERIAL, INCLUDING, BUT NOT LIMITED TO, THE IMPLIED WARRANTIES OF MERCHANTABILITY AND FITNESS FOR A PARTICULAR PURPOSE. SCHROEDER AMERICA shall not be liable for errors contained herein or for incidental consequential damages in connection with the finishings, performance, or use of this material.

This document contains proprietary information which is protected by copyright. All right reserved.

© Copyright 2008 by Schroeder America, all rights reserved.

THIS DOCUMENT CONTAINS IMPORTANT INFORMATION
This manual must be read and understood before the installation and operation of this dispenser.

Schroeder America
5620 Business Park • San Antonio, TX 78218
210.662.8200 • Fax: 210.667.2600 • www.schroederamerica.com
Toll-Free 877.404.2488

1. OVERALL DIMENSIONS

Model:	Width:	Depth:	Height:
S-1	8"	20 1/8"	29"
S-2	16 1/8"	20 1/8"	29"

2. SHIPPING WEIGHT

Model:	Base:	Bowl:
S-1	48lbs	10lbs (1)
S-2	77lbs	10lbs (2)

3. BOWL CAPACITY

Model:	Capacity:
S-1, S-2	5 Gallons (18.9) Liters

4. AMBIENT OPERATING TEMPERATURE

40°F TO 90°F

5. ELECTRICAL REQUIREMENTS

Operating voltage 115V, 60HZ

6. UNPACKING AND INSPECTION

NOTE

This unit was thoroughly inspected before leaving the factory and the carrier has accepted and signed for it. Any damage or irregularities should be noted at time of delivery (or not later than 5 days from date of delivery) and immediately reported to the delivering carrier. Request a written inspection report from Claims Inspector to substantiate any necessary claim. File claim with the delivering carrier, not with Schroeder America.

- A. After unit has been unpacked, remove shipping tape and other material.
- B. Unpack LOOSE-SHIPPED PARTS. Make sure all items are present and in good condition.

7. IDENTIFICATION OF LOOSE-SHIPPED PARTS

- A. SPRAY TUBE BRUSH is used for general cleaning.
- B. SPRAY TUBE ASSEMBLY to be installed after BOWL GASKET and BOWL have been installed.
- C. DRIP TRAY to be installed on unit, then CUP REST to be installed in drip tray.
- D. BOWL COVER to be installed on bowl after bowl has been filled with product.
- E. ALLEN WRENCH used when adjusting drive magnet.

8. SELECTING LOCATION

NOTE

This unit may either be island-mounted or installed on a front or rear counter. Locate unit so the following requirements are satisfied.

- A. Unit must be installed on solid and level countertop.

- B. A minimum of 12 inches air space must be maintained between unit sides and back panels and nearest wall or obstruction to allow for circulating air to cool refrigeration system.
- C. Adequate clearance must be maintained above unit to replenish product supply and also remove bowl cover, bowl, and spray tube for periodic cleaning.
- D. A properly grounded electrical outlet with proper electrical requirements must be provided. Circuit should be fused at 15 amps and no other electrical appliance should be connected to this circuit. ALL ELECTRICAL WIRING MUST CONFORM TO NATIONAL AND LOCAL ELECTRICAL CODES.

9. INSTALLING

IMPORTANT

To comply with NSF Standards, units being used in self-serve locations have to use a non-contact "PULL HANDLE". Order part # 631-0065

A. INSTALLING UNIT

1. Thoroughly wash bowl, bowl cover, bowl gasket, spray tube assembly and evaporator dome with mild soap solution. After washing, thoroughly rinse parts with warm water.
2. Place BOWL upside down on a flat surface. Wet BOWL GASKET with water, then place gasket in bowl with flange down as shown in (figure 4.1, on page 13).
3. Wet evaporator dome (see figure 4.2, on page 13) with damp cloth. Lower bowl around evaporator dome, rocking bowl back to front to facilitate gasket sliding down over dome.
4. Place SPRAY TUBE ASSEMBLY (figure 4.3, on page 13) down into spray tube well in bottom of bowl. Make sure spray tube is pressed down far enough into well until it snaps into place.
5. If applicable, repeat steps 2-4 to install additional bowls and spray tube assemblies.

B. PLACING UNIT IN OPERATING LOCATION

UNIT WEIGHING LESS THAN 80 POUNDS AND WITHOUT FOUR INCH LEVELING LEGS.

1. Place unit in operating location on countertop meeting requirements of SELECTING LOCATION. Make sure unit is sitting level and solid by adjusting the four levelers on the bottom of the unit base.
2. Install DRIP TRAY (on page 12) on unit, then install CUP REST (on page 12) in drip tray.

UNIT WEIGHING MORE THAN 80 POUNDS AND WITHOUT FOUR INCH LEVELING LEGS.

NOTE

To comply with National Sanitation Foundation (NSF) requirements within the United States, unit base must be sealed to counter top.

1. Place unit in operating location on countertop meeting requirements of SELECTING LOCATION.
2. Tilt unit up to expose bottom of base.
3. Remove the four leveling pads on the unit base at each corner.
4. Liberally apply silastic sealant (such as Dow Corning RTV 731 or equivalent) on base bottom edges.

NOTE

Do not move unit after positioning or seal from base to countertop will be broken.

5. Lower unit into operating position on countertop to complete seal from base to countertop.
6. Apply additional sealant around bottom of base. Seal must have a minimum radius of 1/2" to prevent crevices and to ensure a complete seal.
7. Install DRIP TRAY (on page 12) on unit, then install CUP REST (on page 12) in drip tray.

UNIT WITH FOUR INCH LEVELING LEGS

1. Place unit in operating location on countertop meeting requirements of **SELECTING LOCATION**. Make sure unit is sitting level and solid by adjusting the four leveling legs.

5. PREPARATION FOR OPERATION

- A. Mix product as instructed by product manufacturer in preparation to fill unit bowl.
- B. Plug unit power cord into electrical outlet with proper electrical requirements.
- C. Fill bowl with product as instructed.
- D. Install bowl cover, then check for leaks.
- E. Press spray switch, located on lower side(s) of unit, to the "ON" position. Spray tube will begin pumping product to top of bowl.
- F. Press refrigeration switch, located on the lower rear left hand side of unit to the "ON" position.
- G. Allow refrigeration system to operate for 2 to 2 1/2 hours.

6. OPERATION

- A. UNIT EQUIPPED WITH FAUCET
 1. Press cup against faucet bail to dispense product. When cup is full, release bail. On units equipped with PULL handle, grasp handle with one hand while holding cup with the other hand under faucet and pull on handle. Release handle when cup is full.

7. OPERATING CONTROLS AND SWITCHES

- A. ELECTRICAL SWITCHES
 1. Locate spray switch(es) on lower right hand and/or lower left hand side rail support. Forward switch on the left hand rail turns on left hand spray drive motor. Switch(es) on the right hand rail turn on the right hand spray drive motor(s).
 2. Locate refrigeration switch on lower rear left hand side rail support. This switch turns the refrigeration system on and off.
- B. FAUCET BAIL OR PULL HANDLE
 1. Press cup against faucet bail or pull on handle to dispense drink from bowl. Release to stop dispensing.

8. DAILY PRE-OPERATION CHECKS

- A. Make sure bowl contains enough product for proper operation. Stainless steel evaporator can must be covered.

- B. Make sure spray tube assemblies are operating properly and circulating product in bowl.
- C. Make sure drip tray is clean and clean cup rest is in place in drip tray.

WARNING

Disconnect electrical power to unit to prevent personal injury before attempting any internal maintenance. Only QUALIFIED personnel should service internal components or electrical wiring.

9. PERIODIC INSPECTION

- A. Make sure bowl contains sufficient amount of product for proper operation.

IMPORTANT

Dome should always be covered with product.

- B. Make sure spray tube is operating properly to circulate product in bowl.
- C. Check dispensing valve for dripping that may indicate adjustment is required or repair is necessary. If adjustment is required, adjust as instructed.

NOTE

Circulating air, required to cool the refrigeration system condenser coil, is drawn in through grill on back and is discharged out through grills on sides of unit. Restricting air in and out of unit will decrease its cooling efficiency.

IMPORTANT

Condenser coil should be periodically checked for excessive amounts of dust, lint, and grease which will restrict air flow through the coil and cause loss of cooling efficiency. Clean condenser filter as instructed.

- D. Make sure drip tray is clean and clean cup rest is in place in drip tray.

10. ADJUSTMENTS

A. FAUCET DRIP ADJUSTMENTS

Provided faucet internal parts are in good condition, faucet drip may be stopped by performing the following steps:

1. Using a screwdriver, turn pivot pin very slightly to the right (clockwise) or to the left (counterclockwise) until dripping stops.
2. Test dispense faucet and note if faucet drip has stopped after dispensing.

B. ADJUSTING SPRAY DRIVE MAGNET (PAGE 14)

Clearance between spray drive magnet and bottom of platform must be maintained for proper operation of spray tube assembly. Adjust spray drive magnet positioning as follows:

1. Unplug power cord from electrical outlet.
2. Remove drip tray from unit.
3. Remove the two screws securing front panel, then remove panel for access to pump motor and drive magnet.
4. Rotate motor shaft until hex-type set screw is visible on spray drive magnet as shown.

IMPORTANT

Clearance between bottom of platform and spray drive magnet must be 1/16" which is approximate thickness of set screw ALLEN WRENCH.

5. Check clearance between bottom side of platform and spray drive magnet for clearance specified in preceding IMPORTANT note. If clearance is not adequate, loosen set screw and slide spray drive magnet up or down to proper clearance, then securely tighten the set screw. (Page 14)
6. Install front panel and secure with the two screws removed in step 1.
7. Plug power cord into electrical outlet.
8. Test spray system by energizing pump motor via pump motor switch.
9. Install drip tray on unit.

11. CLEANING AND SANITIZING

A. DAILY CLEANING

IMPORTANT

DO NOT wash removed parts in mechanical dishwasher!

1. Place pump switch(es) on side of unit in "OFF" position.
2. Remove bowl cover(s)
3. Remove spray tube assembly by facing front of unit, grasp spray tube at top, then with a brisk snap, push the tube straight back and pull up.
4. Wash spray tube assembly thoroughly in sanitizing solution using CLEANING BRUSH.
5. Install spray tube assembly back inside product bowl. Make sure spray tube assembly is pressed down far enough into well until it snaps into place.
6. Wash bowl cover in sanitizing solution, wipe drip tray with clean cloth, then install on unit.
7. If unit contains more than one bowl and spray tube assembly, repeat preceding steps 2-6 to wash spray tube assemblies and bowl covers.
8. Pour cup of hot water between bowl and cabinet cover to rinse condensation drain tube connect to drip tray.
9. Remove cup rest and drip tray. Wash cup rest and drip tray in warm water, then dry with a clean cloth. DO NOT USE ABRASIVE TYPE CLEANERS.
10. Clean all external surfaces of unit with sponge. Rinse out sponge with clean water, then wring excess water out of sponge and wipe off all external surfaces of unit. Wipe unit dry with soft cloth. DO NOT USE ABRASIVE TYPE CLEANERS.
11. Install cup rest and drip tray on unit.
12. Place pump motor switch(es) in the "ON" position.
13. Dispense product from unit to flush sanitizing solution residue from inside dispensing faucets.

12. SANITIZING

NOTE

Unit should be sanitized every 90 days as instructed following Sanitizer Manufacturer's recommendation.

IMPORTANT

DO NOT wash removed parts in mechanical dishwasher!

- A. Place pump motor switch(es) of units in "OFF" position.
- B. Unplug unit power cord from electrical outlet.
- C. Remove bowl cover(s) and drain remaining product from bowl(s).
- D. Disassemble and clean dispensing faucet(s) as follows:

1. Grasp dispensing valve bonnet. Turn bonnet to the left (counterclockwise), then lift bonnet up and out of valve.
 2. Using CLEANING BRUSH (Item 1), thoroughly clean inside of dispensing valve body with warm water.
 3. Using CLEANING BRUSH, thoroughly clean dispensing valve bonnet with warm water.
 4. Install dispensing valve bonnet in valve body by pushing down on bonnet, then turn bonnet to the right (clockwise) to lock in place.
 5. Disassemble and clean remaining dispensing faucets by repeating step 1-4.
- E. Clean product bowl(s) as follows:
1. Remove spray tube assembly from inside bowl by facing front of unit, grasp spray tube at top, then with a brisk snap, push tube straight back and pull up.
 2. Remove bowl from unit by lifting straight up off evaporator dome.
 3. Wash bowl cover, bowl and gasket, and spray tube assembly in mild soap solutions using CLEANING BRUSH. Rinse with plain water then wipe dry with a clean soft cloth. DO NOT USE ABRASIVE TYPE CLEANERS.
 4. Place bowl upside down on flat surface. Wet bowl gasket with water, then place gasket in bowl with gasket flange down as shown in (figure 4.1, on page 13).
 5. Wet evaporator dome (see figure 2-2) with damp cloth. Lower bowl around evaporator dome rocking bowl from front to back to facilitate gasket sliding down over dome.
 6. Place spray tube assembly down into spray tube well in bottom of bowl. Make sure spray tube assembly is pressed down far enough into well until it snaps into place.
 7. If applicable, repeat preceding steps 1-6 to clean additional bowl covers, bowls, gaskets and spray tube assemblies.
- F. Sanitizing inside of product bowl(s) as follows:
1. Using a clean empty container, prepare 3 gallons of sanitizing solution by using 70°F to 100°F (max) plain water and required sanitizer mix to provide 50 ppm of chlorine.
 2. Pour 3 gallons of mixed sanitizing solution into bowl. Wash inside surface of bowl and external surface of evaporator dome and spray tube assembly with sanitizing solution. MAKE SURE SANITIZING SOLUTION MAKES CONTACT WITH ALL SURFACES INSIDE BOWL.
 3. If unit is equipped with more than one product bowl, repeat preceding steps 1 and 2 to sanitize inside of other product bowl(s).
- G. Install bowl cover(s), then plug unit power cord into electrical outlet.
- H. Place pump motor switch(es) in the "ON" position.
- I. Allow spray tube assembly(s) to operate for a minimum of five minutes, then turn pump motor switch(es) in the "OFF" position.
- J. Unplug unit power cord from electrical outlet.
- K. Dispense all sanitizing solution from product bowl(s)
- L. Mix product as instructed by product manufacturer in preparation to fill product bowls.
- M. Plug unit power cord into electrical outlet, then fill product bowl(s) with product.
- N. Install bowl cover(s), then place pump motor switch(es) in the "ON" position.

13. CLEANING REFRIGERATION CONDENSER COIL

NOTE

Area around unit must be kept free of obstructions at all times. Circulating air, required to cool the condenser coil, is drawn in through grill and filter on back panel and is discharged through grills on sides of unit. Restricting air in and out of unit will decrease cooling efficiency and cause compressor damage.

IMPORTANT

Excessive accumulation of dust, lint, and grease on condenser coil or filter will restrict air flow through condenser coil and cause loss of cooling efficiency. Perform following procedure to clean condenser coil.

- A. Unplug power cord from electrical outlet.
- B. Remove screws securing back panel, then remove panel for access to filter and condenser coil.
- C. Wash filter
- D. Vacuum or use soft brush to clean condenser coil. If available, use low pressure compressed air.
- E. Install filter and back panel and secure with screws.
- F. Plug power cord into electrical outlet.

14. REPLENISHING PRODUCT SUPPLY

- A. Mix product as instructed by product manufacturer.
- B. Place pump motor switch in the "OFF" position.
- C. Remove bowl cover, fill then place pump motor switch in the "ON" position.

15. PRODUCT FLAVOR CHANGE

- A. Sanitize unit as instructed, then fill bowl with new flavor product.

16. TROUBLE SHOOTING

TROUBLE

- 1. Spray tube not operating

POSSIBLE CAUSE

- A. Bowl not properly installed.
- B. Spray tube not properly Installed.
- C. Residue buildup on impeller.
- D. Drive magnet out of adjustment.
- E. Pump motor switch defective.
- F. Pump motor defective.
- G. Pump motor only runs if spray tube is removed.
- H. Starts to pump when turned on, but stops right away.

REMEDY

- A. Make sure bowl is setting squarely on unit & is pushed all the way down.
- B. Make sure spray tube is pushed all the way down in the well and snaps into place.
- C. Remove spray tube and clean thoroughly.
- D. See Adjustment Section for details.
- E. Replace pump motor switch.
- F. Replace pump motor.
- G. Worn impeller shaft or impeller bearing. Replace.
- H. Drive magnet or impeller has lost their magnetism Replace.

- | | | |
|--|---|--|
| 2. Product leaking | <p>A. Bowl gasket improperly installed.</p> <p>B. Worn or damaged bowl gasket.</p> | <p>A. Reinstall bowl gasket. RIBBED SIDE OF BOWL GASKET SHOULD ALWAYS FACE EVAPORATOR DOME BASE. Replace bowl gasket.</p> |
| 3. Compressor does not operate | <p>A. Refrigeration switch in the "OFF" position.</p> <p>B. Product cold enough.</p> <p>C. Unit power cord unplugged.</p> <p>D. No power source. Blown Fuse or tripped circuit breaker.</p> <p>E. Low Voltage.</p> <p>F. Loose, disconnected, or broken wiring.</p> <p>G. Overload protector cut out; overheated compressor. Condenser fan motor not operating.</p> <p>H. Inoperative overload protector or relay.</p> <p>I. Inoperative compressor</p> | <p>A. Turn switch to "ON" position.</p> <p>B. Refrigeration not called for.</p> <p>C. Plug cord into electrical outlet.</p> <p>D. Replace fuse or reset circuit breaker. Note: Fuse is not part of unit. Be sure electrical circuit is not overloaded.</p> <p>E. Voltage must be at least 103 VAC at compressor terminals when compressor is trying to start.</p> <p>F. Tighten or connect connections or replace broken wiring.</p> <p>G. Compressor will not cool enough to restart. Refer to "CONDENSER FAN MOTOR NOT OPERATING" in this section.</p> <p>H. Replace overload or relay.</p> <p>I. Call Schroeder America</p> |
| 4. Compressor operates all the time but product does not cool. | <p>A. Unit located in excessively hot area or air circulation through condenser coil is dirty or clogged.</p> <p>B. System low on refrigerant.</p> | <p>A. Relocate unit or clean condenser and filter.</p> <p>B. Call Schroeder America.</p> |

5. Condenser fan motor does not operate

NOTE: If overload protector cuts out compressor, condenser fan motor will continue to operate; otherwise, troubleshooting condenser fan motor is the same as for "COMPRESSOR DOES NOT OPERATE".

- | | |
|--|---|
| A. Jumper wires loose or disconnected. | A. Tighten connection or replace wires. |
| B. Fan blade obstructed. | B. Remove obstruction. |
| C. Defective condenser fan motor. | C. Replace. |

NOTES:

WIRING DIAGRAM - STARLINE

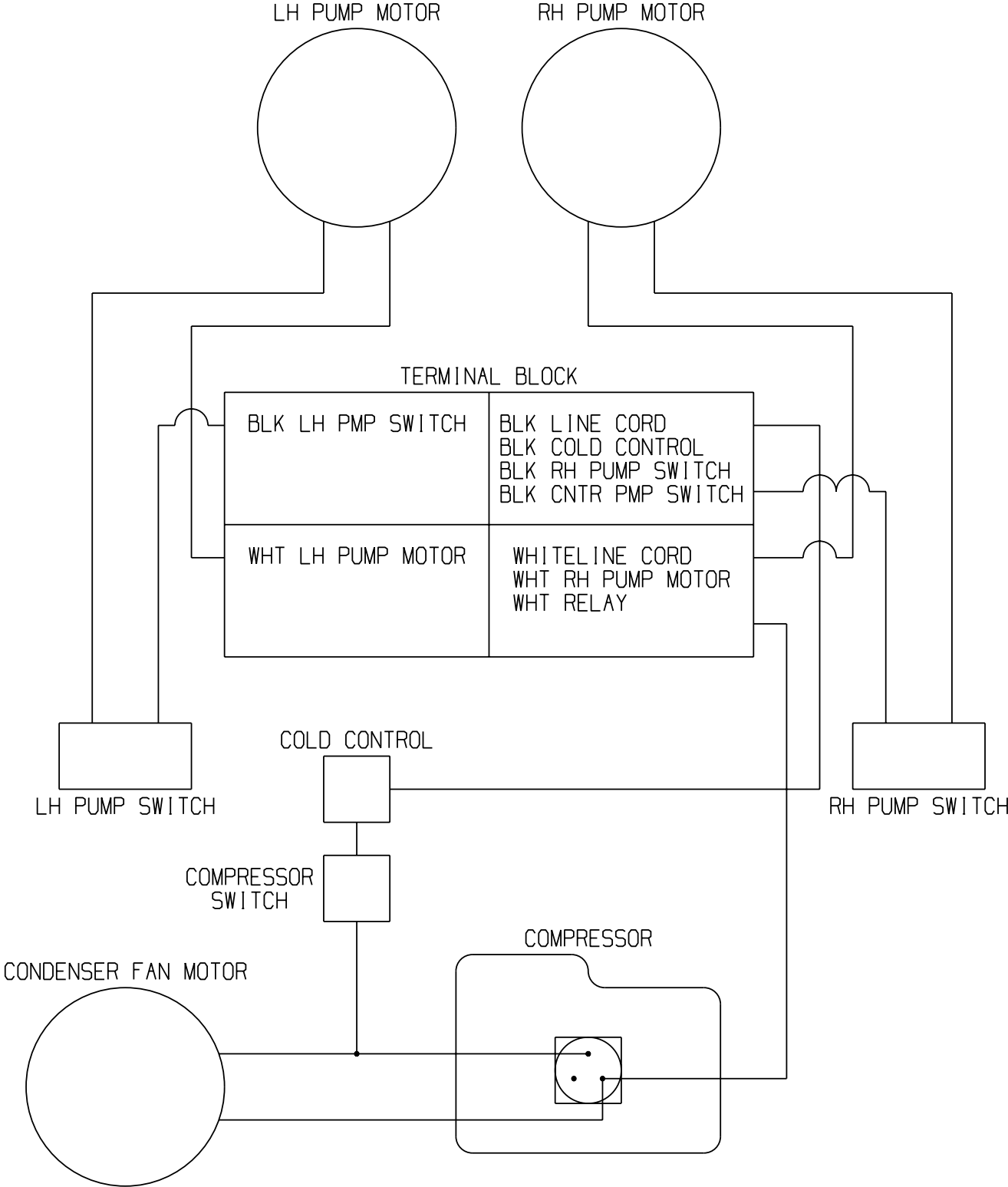
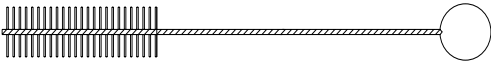
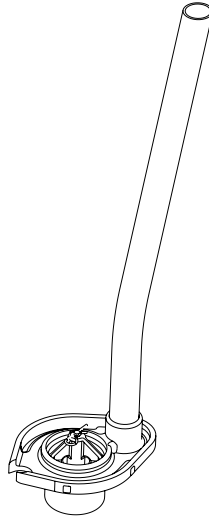

FIGURE 4-3
WIRING DIAGRAM MODELS WITH DANFOSS COMPRESSORS

LOOSE SHIPPED PARTS



BRUSH, SPRAYERS, STARLINE
P.N. 316-0002



SPRAY TUBE & IMPELLER ASSY-5 GAL
P.N. 631-0006

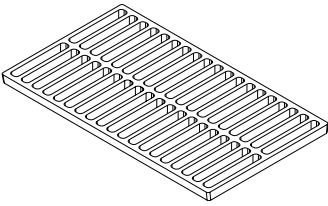

CUP REST - S1
P.N. 265-0016

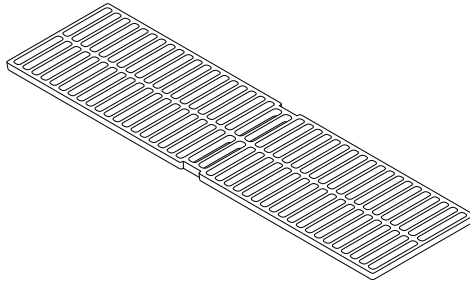

CUP REST - S2
P.N. 265-0057

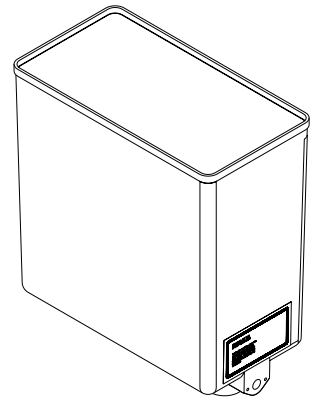

BOWL ASSY W/DECALS
P.N. 631-0008

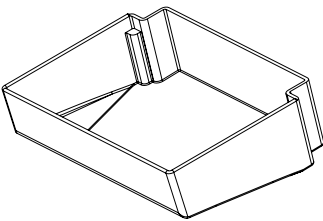

DRIP TRAY - S1
P.N. 265-0064

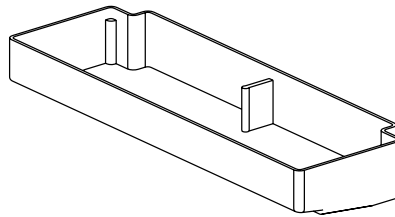

DRIP TRAY - S2
P.N. 265-0222

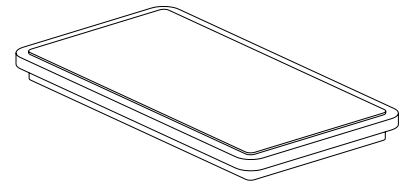

BOWL COVER
P.N. 265-0050

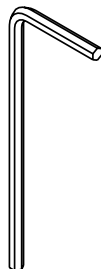

WRENCH, ALLEN, .078 HEX
P.N. 316-0001

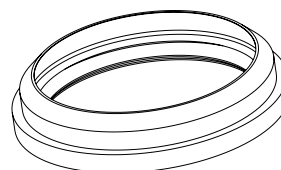

GASKET, BOWL - S1, S2,
P.N. 210-0004

INSTALLATION DIAGRAMS

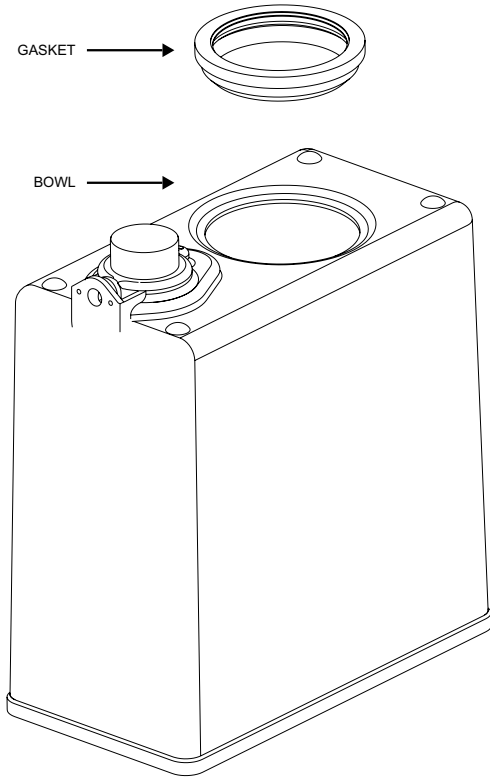

FIG. 4.1
INSTALLING BOWL GASKET

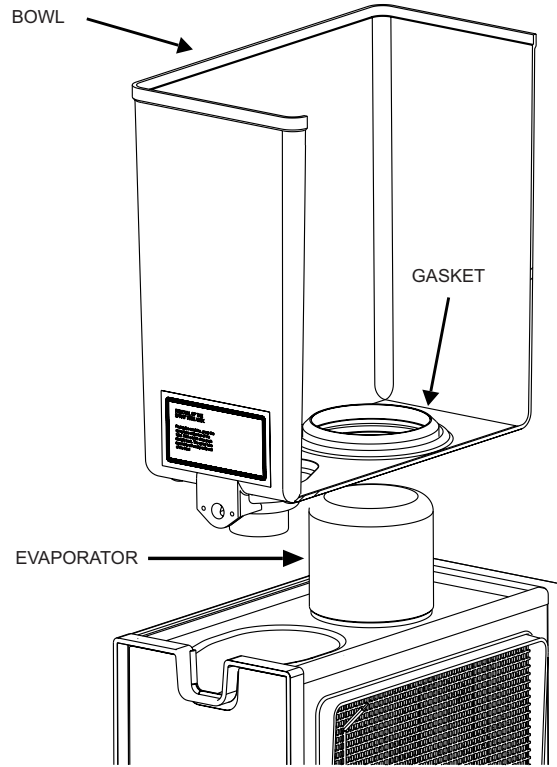

FIG. 4.2
INSTALLING BOWL

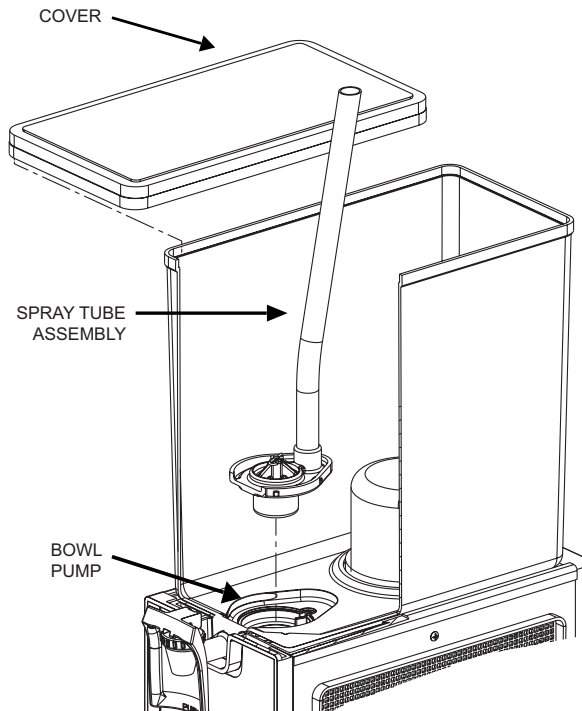
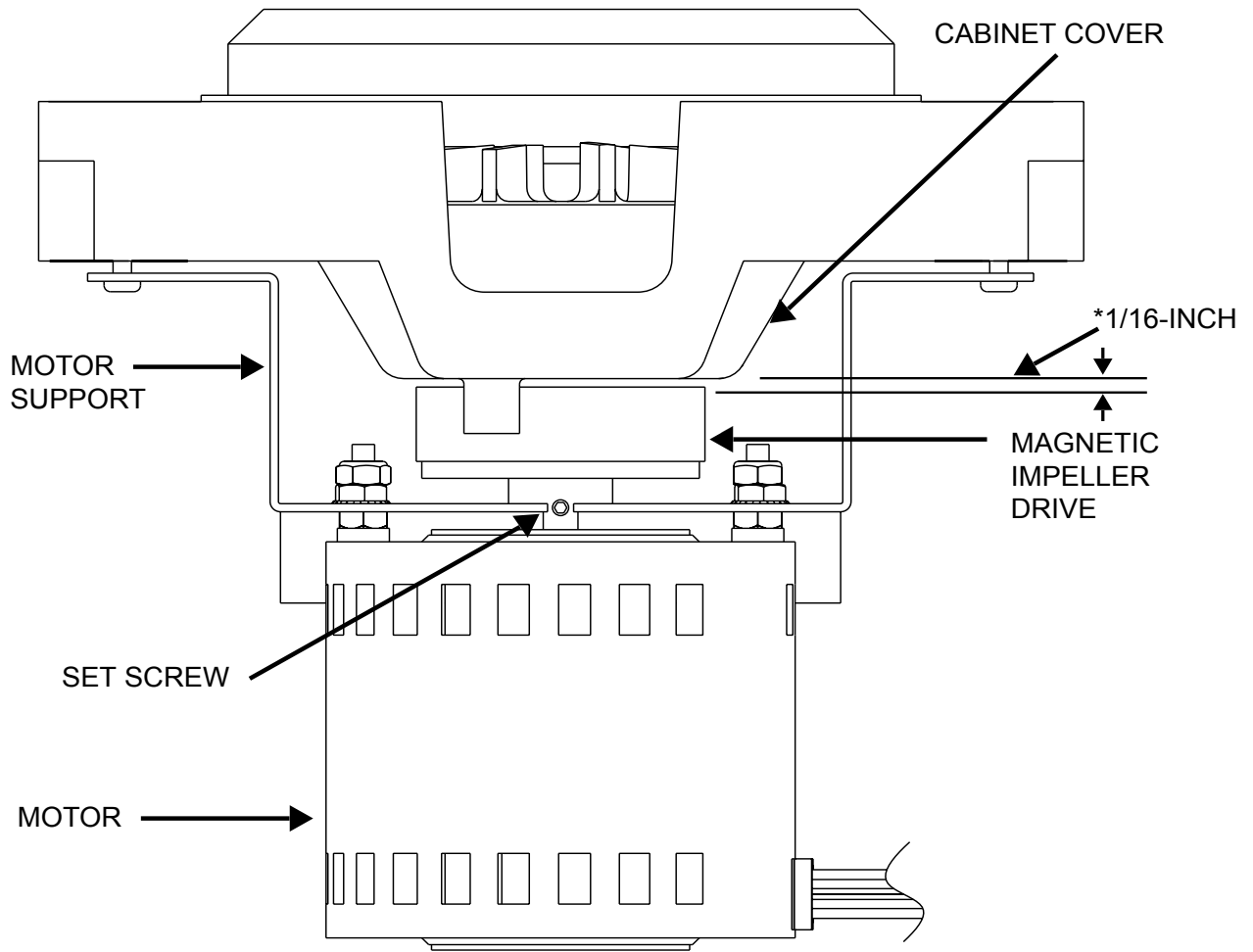

FIG. 4.3
INSTALLING SPRAY
TUBE ASSEMBLY

MAGNETIC IMPELLER DRIVE MOTOR ASSEMBLY



*** IMPORTANT**

Clearance between bottom side of cabinet cover and magnetic impletter drive must be 1/16-inch which is the approximate of the allen wrench used to loosen the hex-type setscrews.

FAUCET PARTS AND ASSEMBLIES

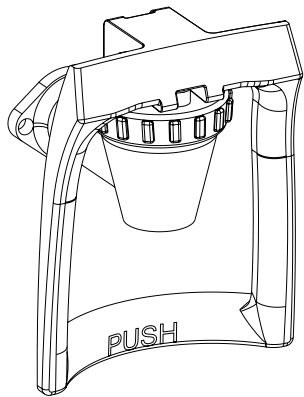
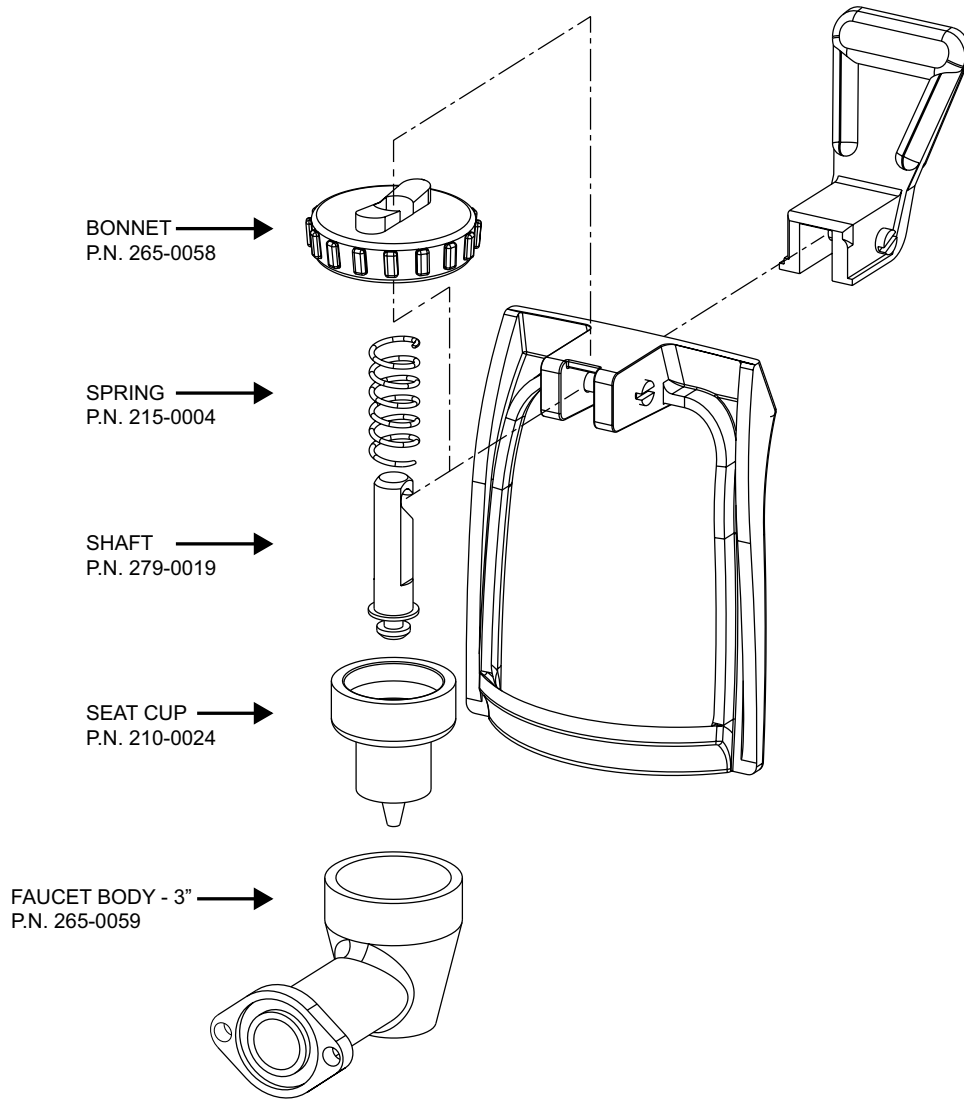

FAUCET ASSY 3"
P.N. 645-0005

3" FAUCET ASSY W/FAUCET
BAIL - "S" SERIES
(INCLUDES (2) P.N. 220-0008 SCREWS
AND (1) 208-0115 O-RING

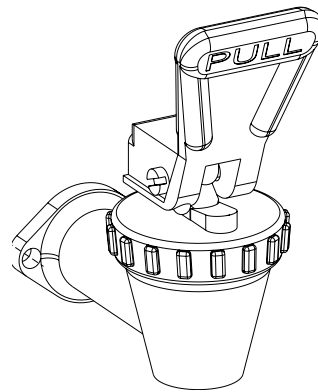

FAUCET ASSY. W/PULL HANDLE
P.N. 645-0119

3" FAUCET ASSY W/PULL
HANDLE - "S" SERIES
(INCLUDES (2) P.N. 220-0008 SCREWS
AND (1) 208-0115 O-RING

STARLINE SINGLE BOWL ASSEMBLY

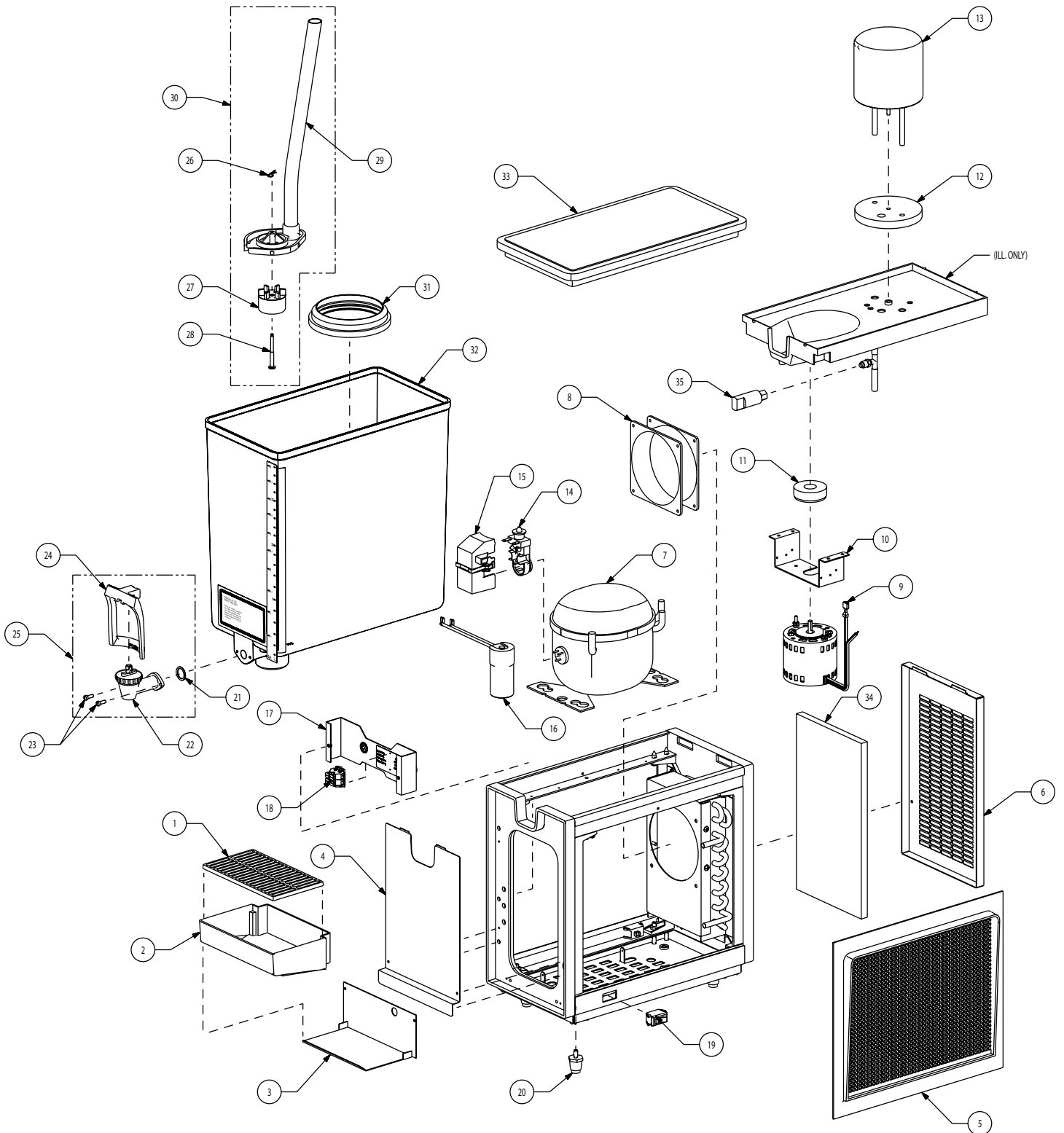

STARLINE SINGLE BOWL ASSEMBLY PART NUMBERS

#	<u>NEW PART#</u>	<u>OLD PART#</u>	<u>DESCRIPTION</u>
1	265-0016	04-2250-039	Cup Rest
2	265-0064	04-2240-039	Drip Tray
3	319-0008	96-0681-000	Drip Tray Panel
4	319-0183	04-0188-000	Front Panel
5	265-0337	04-1250-000	Grill, Side
6	319-0178	96-0717-001	Panel, Rear
7	300-0001	96-0980-000	Compressor, Danfoss
8	503-0003	04-0212-000	Fan Motor
9	304-0001	04-1209-000	Pump Motor
10	319-0177	04-0209-000	Pump Mtg Bracket
11	645-0009	04-1190-000	Impeller Drive Assy w/set screw
12	210-0002	04-0321-000	Gasket, Evaporator
13	645-0028	96-0614-000	Evap. Dome Assy w/thermowell
14	507-0024	96-0983-000	Relay
15	631-0014	96-0982-000	Cover
16	507-0018	96-0981-000	Start Cap
17	319-0187	18-7879-001	Bracket, Terminal Block
18	506-0015	18-7877-000	Terminal Block Assy
19	505-0001	04-0255-000	Spary/Ref. Switch
20	234-0003	04-5021-000	Leg, Leveller
21	208-0115	04-1061-000	O-ring, Faucet
22	637-0001	04-1072-039	Faucet Body Assy
23	220-0008	04-1071-000	Screw, Faucet Mtg
24	631-0007	04-0800-039	Bail Faucet
25	645-0005	04-1070-000	3" Faucet Assy
26	247-0001	04-1015-000	Hitch Pin
27	645-0002	04-0261-000	Impeller Assy
28	279-0006	04-1016-000	Impeller Shaft
29	631-0005	96-0609-000	Spray Tube/Knob
30	631-0006	96-0610-000	Spray Tube/Impeller Assy
31	210-0004	04-1020-000	Bowl Gasket
32	631-0008	04-1050-200	Bowl Assy
33	265-0050	04-1030-011	Bowl Cover
34	286-0005		Filter
35	505-0014		Control, Low Pressure

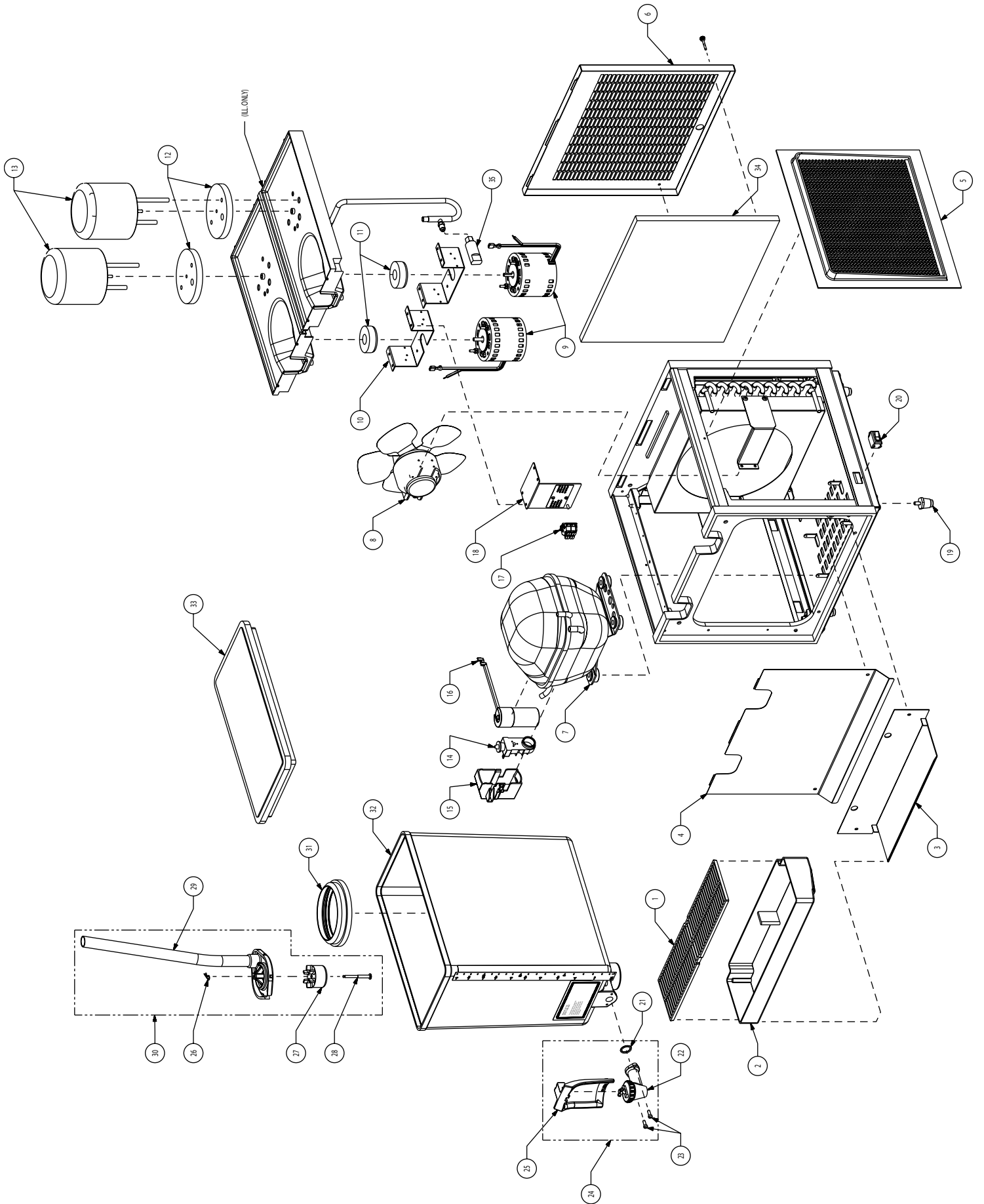

STARLINE DUAL BOWL ASSEMBLY PART NUMBERS

<u>#</u>	<u>NEW PART#</u>	<u>OLD PART#</u>	<u>DESCRIPTION</u>
1	265-0057	04-1360-039	Cup Rest
2	265-0222	04-1340-039	Drip Tray
3	319-0011	96-0887-000	Drip Tray Panel
4	319-0174	96-0886-000	Front Panel
5	265-0337	04-1250-000	Grill, Side
6	319-0171	96-0710-001	Panel, Rear
7	300-0002	96-0985-000	Compressor, Danfoss
8	304-0005	96-1015-000	Fan Motor
9	304-0001	04-1209-000	Pump Motor
10	319-0177	04-0209-000	Pump Mtg Bracket
11	645-0009	04-1190-000	Impeller Drive Assy w/set screw
12	210-0002	04-0321-000	Gasket, Evaporator
13	645-0028	96-0614-000	Evap. Dome Assy w/thermowell
14	507-0009	96-0624-000	Relay
15	631-0014	04-1803-000	Cover
16	507-0008	96-0986-000	Start Cap
17	506-0015	18-7877-000	Terminal Block Assy
18	319-0184	18-7878-001	Bracket, Terminal Block
19	234-0003	04-5021-000	Leg, Leveller
20	505-0001	04-0255-000	Spary/Ref. Switch
21	208-0115	04-1061-000	O-ring, Faucet
22	637-0001	04-1072-039	Faucet Body Assy
23	220-0008	04-1071-000	Screw, Faucet Mtg
24	645-0005	04-1070-000	3" Faucet Ass
25	631-0007	04-0800-039	Bail Faucet
26	247-0001	04-1015-000	Hitch Pin
27	645-0002	04-0261-000	Impeller Assy
28	279-0006	04-1016-000	Impeller Shaft
29	631-0005	96-0609-000	Spray Tube/Knob
30	631-0006	96-0610-000	Spray Tube/Impeller Assy
31	210-0004	04-1020-000	Bowl Gasket
32	631-0008	04-1050-200	Bowl Assy
33	265-0050	04-1030-011	Bowl Cover
34	286-0004		Filter, S
35	505-0014		Control, Low Pressure



PARTS AND EQUIPMENT LIMITED COMMERCIAL WARRANTY FOR STARLINE BEVERAGE EQUIPMENT

Schroeder America does warrant to the original purchaser from Schroeder America, who purchase solely for commercial or industrial uses, or for resale in the ordinary course of business, that each of the Products covered by this Commercial Warranty shall be free from defects in material and or workmanship, under normal and proper use and service conditions. Any Products covered by this Commercial Warranty (including components thereof) demonstrated to have been defective when shipped by Schroeder America, will be either repaired, replaced (with new or rebuilt replacement) or the purchase price thereof refunded, as Schroeder America may determine solely, in its discretion. A product or component thereof covered by this Commercial Warranty supplied as Warranty Replacement will assume the balance of the Period of Warranty applicable to the original measured from the date of replacement. This Commercial Warranty does not include, and Schroeder America will not assume or pay, the expense of any repair, replacement, analysis or any other service or parts furnished by any party other than Schroeder America unless specifically authorized in writing by Schroeder America. This Commercial Warranty does not include labor for diagnosis, removal, or installation on any products or components.

Products covered by this Commercial Warranty include all beverage dispensing equipment manufactured or sold by Schroeder America after the date hereof (not excluded hereinafter) and this Commercial Warranty is further limited to the use of that equipment in connection with juice, soft drinks syrups, coffee, hot chocolate, tea or commodities for which use the particular product has been identified by Schroeder America.

Specific exclusions to this Commercial Warranty are OEM Sales, water filter cartridges, light bulbs, fuses, diaphragms, seals, o-rings, silicone or rubber parts, refrigeration access valves or related refrigeration leaks, parts in contact with water or the product dispensed and which has become inoperative due to scale or chemical change, and normal maintenance items. This Commercial Warranty will also **specifically exclude** damage resulting from improper voltage, inadequate wiring, abuse, accident, alteration, misuse, neglect, unauthorized repair, improper cleaning or failure to follow installation, operating or maintenance instructions.

The Period of Warranty is (i) one (1) year from the date of installation, or (ii) fifteen (15) months from the date of shipment by Schroeder America of a product covered hereby, whichever time period elapses first. For products incorporating a sealed refrigeration system the Period of Warranty, with respect to the sealed refrigeration system only (defined as the compressor, evaporator, condenser, and interconnection tubing [not to include access valves]), is three (3) years from the date of installation or forty (40) months from the date of shipment by Schroeder America, whichever time period elapses first.

Any claim under this Commercial Warranty must be made as promptly as is reasonable possible, but in no event later than (30) thirty consecutive calendar days, after the discovery of the defect. Such claims are to be directed to Schroeder America. Repair or replacement of the sealed refrigeration system under warranty will be at Schroeder America, San Antonio, TX. Schroeder America at its discretion may ship a replacement refrigeration chassis to customer for exchange. Customer will use all external parts of original dispenser and ship defective chassis to Schroeder America (to be determined by Schroeder America.) freight pre-paid. If unit damage is a result of one of the **specific exclusions** mentioned above, customer will be charged a \$150 restocking fee.

Under no circumstances should the entire unit be returned to Schroeder America except for repair or replacement of the sealed refrigeration system. Whenever a product is returned to Schroeder America for repair or replacement of the sealed refrigeration system under the terms of the Commercial Warranty and the defect is found to exist in parts other than the sealed refrigeration system (example thermostat, pump motors, condenser fan motor, start capacitor, relay or overload), an evaluation fee of fifty dollars (\$50.00) may be charged. If such defective part needs replacement or repair and is within its Period of Warranty, such part will be replaced or repaired at no charge, except for labor for removal and installation of such part; if not within its Period of Warranty a charge for such part and labor will be made.

The product covered by this Commercial Warranty, or components thereof, must not be returned to Schroeder America without prior authorization. Instructions for return will be given with any such authorization. All returned products and or parts must be shipped prepaid to Schroeder America. Return shipping costs of repaired or replacement products or parts will be prepaid by Schroeder America except to original purchasers in Hawaii or Alaska, in which case Schroeder America will pay shipping costs only to Seattle, San Francisco, or Los Angeles respectively. Schroeder America will not accept collect shipments. Replaced products or parts become the property of Schroeder America. Any product or parts returned to Schroeder America under the terms of this Commercial Warranty must be accompanied by a Returned Goods Tag, properly filled out as to unit model number and serial number and detailed explanation of failure. Returned Goods Tags will be furnished by Schroeder America. Except for descriptions of size, quantity and type, which may appear on Schroeder America invoices and other written materials, and except for any statements of conformity of Schroeder America product with specification of certain industry, government or professional organizations standards, which may appear as product information disclosures in Schroeder America literature and other documents from time to time, THIS COMMERCIAL WARRANTY IS IN LIEU OF AND EXCLUDES ALL OTHER WARRANTIES, EXPRESS OR IMPLIED, INCLUDING WARRANTIES OF MERCHANTABILITY AND FITNESS FOR A PARTICULAR PURPOSE.

SCHROEDER AMERICA LIABILITIES ARE LIMITED SOLELY AND EXCLUSIVELY TO THE REPLACEMENT OR REPAIR OF THE DEFECTIVE PRODUCT OR REFUND OF THE PURCHASE PRICE OF SAID PRODUCT. SCHROEDER AMERICA IS NOT LIABLE FOR ANY SPECIAL, INCIDENTAL OR CONSEQUENTIAL DAMAGES OF ANY KIND WHATSOEVER, WHETHER ANY CLAIM FOR RECOVERY IS BASED ON THEORIES OF CONTRACT, NEGLIGENCE OR TORT. Without limitation, these liabilities do not include shipping charges, labor, installation or any other losses or expenses incurred on operation or installation of any replaced, repaired, or returned product or component. In those Jurisdictions where liability for damages cannot be disclaimed, the original purchaser's recovery shall not exceed the cost of the product to which this Commercial Warranty may apply.

Schroeder America neither assumes, nor authorizes any salesperson, distributor, employee, agent, or other person to assume for it, any liability or obligation of any kind which is difference from the terms of this Commercial Warranty.

SCHROEDER AMERICA MAKES NO WRITTEN WARRANTY OF ANY KIND WHATSOEVER TO ANY PURCHASER WHO BUYS FOR PERSONAL, FAMILY OR HOUSEHOLD USE.

Schroeder America may in its discretion direct an Authorized Service Center reasonably proximate to the Original Purchaser to perform its obligations under this Commercial Warranty. That Service Center may also perform such other services as the purchaser may require at purchaser's expense.

Schroeder America
5620 Business Park • San Antonio, Texas 78218 • www.schroederamerica.com
Phone: 210.662.8200 • Fax: 210.667.2600 • Toll Free: 877.404.2488

REV: 03/01/08
PN: 810-0015

